

specialized grilles



metric sizes



duct mounted



sight proof design



doors / partitions



factories



airport terminals



humid areas



open areas



MRI compatible



gymnasiums



rugged areas

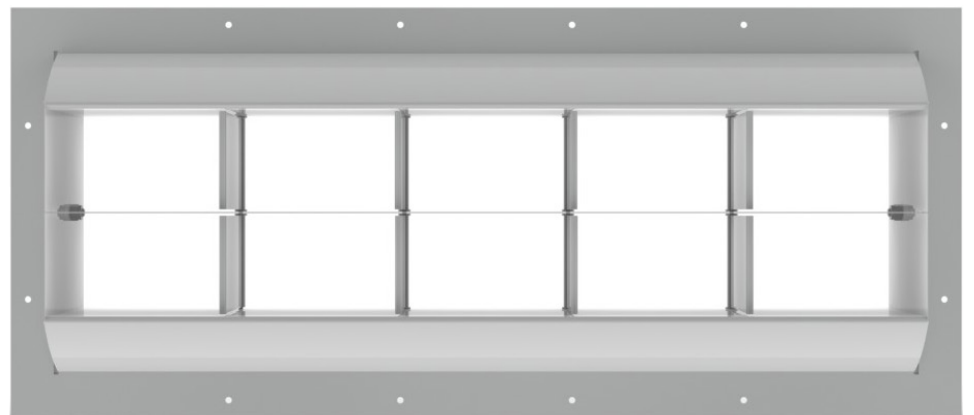

Table of Contents

specialized grille products

Specialized Grille Products..... 14

overview

Overview..... 110
Application Icons Key..... 110

eggcrate return grilles

Eggcrate Return Grilles 112
 50F Aluminum Border, 50F-NT Aluminum / Narrow Tee 112
 Dimensions..... 113
 45F 114
 Dimensions..... 115
 50R-SS Stainless Steel 116
 Dimensions..... 117
 45R-SS Stainless Steel 118
 Dimensions..... 119
 50FF Aluminum / Filter Return 120
 Dimensions..... 121
 50F, 50F-NT, 50R-SS, & 50FF Performance Data 122
 45F & 45R-SS Performance Data 124

perforated return grilles

Perforated Return Grilles..... 125
 8F Aluminum 125
 8FF Aluminum Filter Return 125
 8R Steel 125
 8RF Steel Filter Return 125
 8SS 304 Stainless Steel..... 125
 Dimensions..... 126
 Performance Data 127

steel heavy duty bar return grilles

Steel Heavy Duty Bar Return Grilles 129
 33(RL / RS) / 38° Deflection 129
 30(RL / RS) / 0° Deflection 129
 Dimensions..... 130
 33(RFL / RFS) / 38° Deflection / Filter 131
 30(RFL / RSF) / 0° Deflection / Filter 131
 Dimensions..... 132
 Performance Data 133

aluminum heavy duty bar return grilles

Aluminum Heavy Duty Bar Return Grilles..... 137
 63(FL / FS) / 30° Deflection 137
 60(FL / FS) / 0° Deflection 137
 Dimensions..... 138
 Performance Data..... 139

spiral duct mounted grilles

Spiral Duct-Mounted Grilles.....	143
S301(FL / FS) / Single Deflection / Radius End Caps / Supply	143
S300(FL / FS) / Double Deflection / Radius End Caps / Supply	143
Dimensions.....	144
US301(FL / FS) / Single Deflection / Universal End Caps / Supply	145
US300(FL / FS) / Double Deflection / Universal End Caps / Supply	145
Dimensions.....	146
S8F / Radius End Caps / Perforated Return	147
US8F / Universal End Caps / Perforated Return	147
Dimensions.....	148
Performance Data.....	149

door grilles

Door Grilles.....	153
T-700(L / S) / Steel.....	153
Dimensions.....	154
CT-700(L / S) / Aluminum.....	155
Dimensions.....	156
Performance Data.....	157

reversible core narrow blade grilles

Reversible Core Narrow Blade Grilles.....	158
1700(L / S).....	158
Dimensions.....	159
Performance Data.....	160

commercial / industrial louvered supply grilles

Commercial/Industrial Louvered Supply Grilles.....	162
JFA (L / S) / Pole Operated.....	162
Dimensions.....	163
Performance Data.....	164

drum louvers

Drum Louvers.....	167
DL.....	167
Dimensions.....	168
DL-SV.....	169
Dimensions.....	170
Performance Data.....	171
S-DL, S-DL-SV.....	172
Dimensions.....	173
Performance Data.....	176
US-DL, US-DL-SV.....	178
Dimensions.....	179
Performance Data.....	180

options & accessories

Options & Accessories.....	182
Hinge Locations.....	185

pages: 112-124

eggcrate return grilles

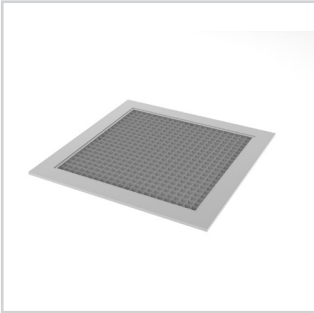

50F

RETURN GRILLE

- Aluminum border & grid
- Available in 3 grid core sizes
- Highest free area of any return grille
- MRI compatible



50F-NT

RETURN GRILLE - NARROW TEE

- Designed to fit narrow tee ceiling grids
- Aluminum border & grid
- Available in 3 grid core sizes
- Highest free area of any return grille

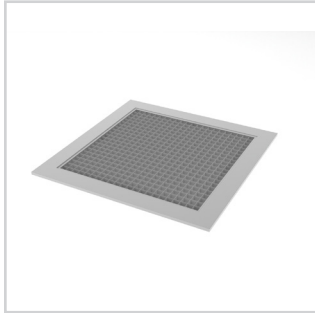

50R

RETURN GRILLE

- Steel border & aluminum grid
- Can be used in fire-rated applications
- Available in 3 grid core sizes
- Highest free area of any return grille

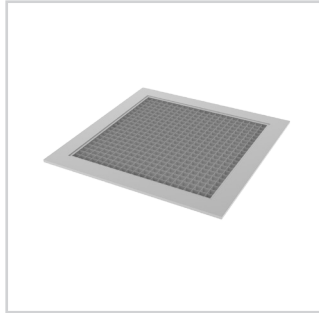

50R-SS

RETURN GRILLE

- Stainless steel border & grid
- 1/2" x 1/2" x 1/2" core
- Highest free area of any return grille

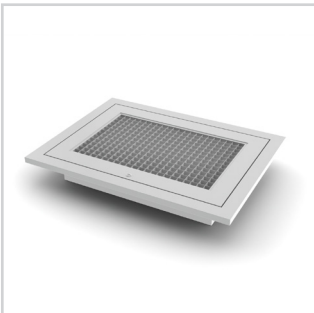

50FF

RETURN FILTER GRILLE

- Aluminum border & grid
- 1/2" x 1/2" x 1/2" core
- Highest free area of any return grille



45F

RETURN GRILLE

- Aluminum border & grid
- 45° deflection sight proof design
- MRI compatible

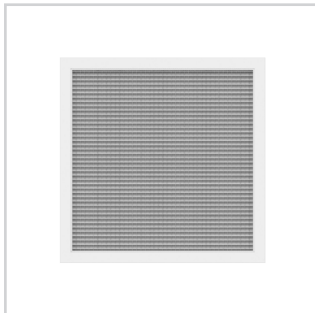

45R-SS

RETURN GRILLE

- Stainless steel border & grid
- 45° deflection sight proof design

pages: 125-128

perforated return grilles

			
<p>8F</p>	<p>8FF</p>	<p>8R</p>	<p>8RF</p>
<p>RETURN GRILLE</p> <ul style="list-style-type: none"> • Aluminum construction • 51% free area perforated face • Matches appearance of perforated supply diffusers 	<p>RETURN FILTER GRILLE</p> <ul style="list-style-type: none"> • Aluminum construction • 51% free area perforated face • Matches appearance of perforated supply diffusers • Accommodates 1" or 2" thick filters 	<p>RETURN GRILLE</p> <ul style="list-style-type: none"> • Steel construction • 51% free area perforated face • Matches appearance of perforated supply diffusers 	<p>RETURN FILTER GRILLE</p> <ul style="list-style-type: none"> • Steel construction • 51% free area perforated face • Matches appearance of perforated supply diffusers • Accommodates 1" or 2" thick filters

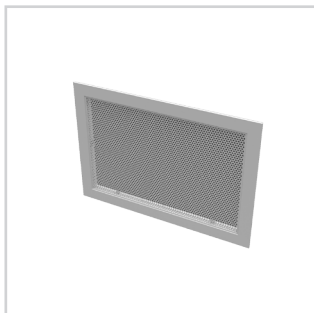

8SS

RETURN GRILLE

- Stainless steel construction (#304)
- 51% free area perforated face
- Matches appearance of perforated supply diffusers

pages: 129-136

steel heavy duty bar return grilles



33 (RL / RS)

HEAVY DUTY RETURN GRILLE

- Steel construction
- 1/2" blade spacing
- 38° fixed deflection
- Great for use in gymnasiums and areas where rugged construction is required



30 (RL / RS)

HEAVY DUTY RETURN GRILLE

- Steel construction
- Blade spacing is 3/8"
- 0° fixed deflection
- Great for use in gymnasiums and areas where rugged construction is required



33 (RFL / RFS)

HEAVY DUTY FILTER RETURN GRILLE

- Steel construction
- 1/2" blade spacing
- 38° fixed deflection
- Accommodates 1" or 2" thick filters
- Great for use in gymnasiums and areas where rugged construction is required



30 (RFL / RFS)

HEAVY DUTY FILTER RETURN GRILLE

- Steel construction
- Blade spacing is 3/8"
- 0° fixed deflection
- Accommodates 1" or 2" thick filters
- Great for use in gymnasiums and areas where rugged construction is required

pages: 137-142

aluminum heavy duty bar return grilles



63 (FL / FS)

HEAVY DUTY RETURN GRILLE

- Aluminum construction
- 1/2" blade spacing
- 30° fixed deflection
- MRI compatible
- Great for use in gymnasiums and areas where rugged construction is required

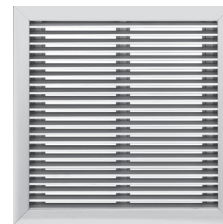

60 (FL / FS)

HEAVY DUTY RETURN GRILLE

- Aluminum construction
- 1/2" blade spacing
- 0° fixed deflection
- Great for use in gymnasiums and areas where rugged construction is required

pages: I43-I52

spiral duct mounted grilles

			
<p>S301 / S300 (FL / FS)</p> <p>SINGLE / DOUBLE DEFLECTION SPIRAL GRILLES</p> <ul style="list-style-type: none"> • Mounts directly to duct, eliminating need for duct taps • Radius end cap design to match duct diameter • Aluminum construction • Individually adjustable blades 	<p>US301 / US300 (FL / FS)</p> <p>SINGLE / DOUBLE DEFLECTION SPIRAL GRILLES</p> <ul style="list-style-type: none"> • Mounts directly to duct, eliminating need for duct taps • Universal end cap design can be used on multiple duct diameters • Aluminum construction • Individually adjustable blades 	<p>S8F</p> <p>PERFORATED SPIRAL GRILLE</p> <ul style="list-style-type: none"> • Radius end cap design to match duct diameter • Mounts directly to duct, eliminating need for duct taps • Aluminum construction • Perforated face, 51% free area 	<p>US8F</p> <p>PERFORATED SPIRAL GRILLE</p> <ul style="list-style-type: none"> • Universal end cap design can be used on multiple duct diameters • Mounts directly to duct, eliminating need for duct taps • Aluminum construction • Perforated face, 51% free area

pages: I53-I57

door grilles

	
<p>T-700 (L / S)</p> <p>DOOR GRILLE</p> <ul style="list-style-type: none"> • Steel construction • Great for use in doors or partitions • Sight proof design with large free area • Optional auxiliary frame to facilitate mounting 	<p>CT-700 (L / S)</p> <p>DOOR GRILLE</p> <ul style="list-style-type: none"> • Aluminum construction • Great for use in doors or partitions • Sight proof design with large free area • Optional auxiliary frame to facilitate mounting

pages: I58-I61

reversible core grilles

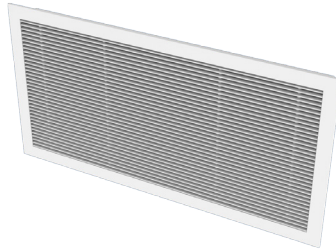

1700 (L / S)

NARROW BLADE GRILLES

- Extruded aluminum construction
- Reversible core for 5° or 15° deflection
- Core easily removes using a detachable lever
- Available with rear deflection blades

pages: I62-I66

commercial / industrial louvered supply grilles

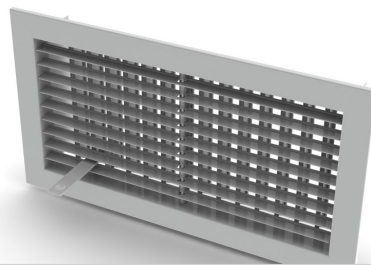

JFA (L / S)

POLE OPERATED GRILLES

- Steel & aluminum construction
- Individually adjustable aluminum front blades
- Steel rear blades are gang operated
- Pole operated rear blades ganged for easy adjustment
- Extruded aluminum front blades individually adjustable

pages: 167-181

drum louvers

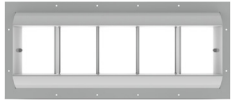

DL

DRUM LOUVER

- High capacity with long throws
- Adjustable vertical blades mounted in rotating drum
- Aluminum construction
- Great for large open areas where air must be discharged over a large distance

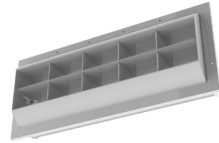

DL-SV

DRUM LOUVER - SPLIT VANE

- Split vane design for increased flexibility
- High capacity with long throws
- Adjustable vertical blades mounted in rotating drum
- Great for large open areas where air must be discharged over a large distance

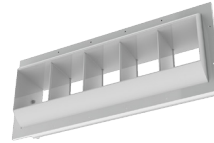

US-DL

SPIRAL DUCT DRUM LOUVER

- Mounts directly to duct, eliminating need for duct taps
- Universal end cap design can be used on multiple duct diameters
- High capacity with long throws, great for large open areas
- Adjustable vertical blades mounted in rotating drum

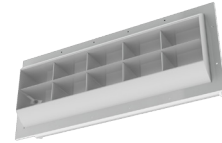

US-DL-SV

SPIRAL DUCT DRUM LOUVER - SPLIT VANE

- Mounts directly to duct, eliminating need for duct taps
- Universal end cap design can be used on multiple duct diameters
- Split vane design for increased flexibility
- Adjustable vertical blades mounted in rotating drum

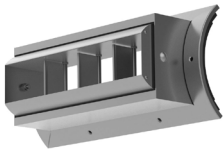

S-DL

SPIRAL DRUM LOUVER

- High capacity with long throws
- Mounts directly to duct eliminating the need for taps
- Great for large open areas where air must be discharged over a large distance

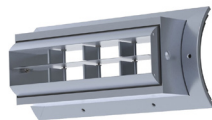

S-DL-SV

SPIRAL DRUM LOUVER - SPLIT VANE

- Split vane design for increased flexibility
- High capacity with long throws
- Adjustable vertical blades mounted in rotating drum
- Great for large open areas where air must be discharged over a large distance

Overview

Titus offers a complete line of specialty grilles for the various types of nonstandard applications that require special air distribution products. Titus specialty grilles are designed to provide the highest degree of quality and performance. The comprehensive line includes:

- Perforated and eggcrate return grilles to match the look and feel of perforated diffusers or parabolic lighting fixtures
- Heavy duty supply and return grilles for rugged applications like gymnasiums
- Transfer and door grilles with sight proof design
- Narrow blade reversible core grilles
- High capacity drum louvers in single or split vane design
- Spiral mount grilles designed to mount directly onto spiral ductwork without the need for saddle taps
- Heavy gauge supply grilles with lever operator for industrial applications

Redefine your comfort zone™ | www.titus-hvac.com



APPLICATION ICONS KEY



prevents line of sight through the grille

sight proof design



great for areas where the conditioned space is large and the ductwork is unable to be brought closer to the occupants

open areas



for use in doors and partitions

doors / partitions



for use in MRI environments & will not significantly affect the diagnostic information

MRI compatible



for use in factories, warehouses, shopping malls and other large open spaces where long throws are required

factories



for use in gymnasiums, arenas and other large open spaces where long throws are required

gymnasiums



used in airport terminals and other large open spaces where long throws are required

airport terminals



for use in areas where rugged construction is required

rugged areas



especially suited to work in areas where high humidity may become a factor

humid areas



mounts directly to ductwork

duct mounted



Diffuser module sizes are hard metric & inlets are soft. Metric linear and grille products are converted to the nearest 1/4" for ordering. Contact us for more information.

metric sizes

Function	Description	Deflection	Blade Spacing	Front Blades	
				Horizontal	Vertical
Supply	Reversible Core Narrow Blade	15° Up, 15° Down, 5° Up, or 5° Down	Narrow	1700L (For Double Deflection use 1700L-07)	1700S (For Double Deflection use 1700S-07)
	Gang Operated Rear Blades Using Pole	Double	3/4" Front 1 1/4" Rear	JFA-L	JFA-S
	High Capacity, Long Throw Commercial/ Industrial Grille in Rotating Drum	Single	Varies with Model	-	DL
	Spiral Duct Grille - Radius Endcap	Double	3/4"	S300FL	S300FS
	Spiral Duct Grille - Radius Endcap	Single	3/4"	S301FL	S301FS
	Spiral Duct Grille - Universal Endcap	Double	3/4"	US300FL	US300FS
	Spiral Duct Grille - Universal Endcap	Single	3/4"	US301FL	US301FS
Return	Eggcrate Return	0° 45°	1/2" x 1/2" x 1/2" grid 1/2" x 1/2" x 1" grid 1" x 1" x 1" grid	50F / 50R-SS 45F / 45R-SS	50F / 50R / 50R-SS 45F / 45R-SS
	Perforated Return	N/A	3/16" Holes on 1/4" staggered centers	8F / 8R / 8SS	8F / 8R / 8SS
	Heavy Duty Gym Grille	0°	3/8"	30RL	30RS
		0°	1/2"	60FL	60FS
		38°	1/2"	33RL	33RS
		30°	1/2"	63FL	63FS
	Steel Door Grille	Sight Proof	1/2"	T-700	N/A
	Aluminum Door Grille	Sight Proof	1/2"	CT-700	N/A
	Eggcrate Filter Grille*	N/A	1/2" x 1/2" x 1/2" grid	50FF	50FF
	Eggcrate Filter Grille*	45°	1/2" x 1/2" x 1/2" grid	45F	-
	Perforated Filter Grille*	0°	3/16" Holes on 1/4" staggered centers	8FF / 8RF	8FF / 8RF
	Gym Filter Grille*	0°	3/8"	30RFL	30RFS
		38°	1/2"	33RFL	33RFS
Spiral Duct Grille - Radius end caps	Perforated	3/16" Holes on 1/4" staggered centers	S8F	S8F	
Spiral Duct Grille - Universal end caps	Perforated	3/16" Holes on 1/4" staggered centers	US8F	US8F	

Available Material Types	Model																						
	Supply									Return													
	1700	1700-07	JFA	DL	S300	S301	US300	US301	45	50	8	CT-700	30	8	33	T-700	30	33	60	63	S8	US8	
A	•	•		•	•	•	•	•	•	•	•	•	•	•	•	•	•	•	•	•	•	•	•
S																							
SS										•	•			•									
SA			•							•													

Note: A = Aluminum Border and Blades, S = Steel, SS = 304 Stainless Steel, SA = Steel Border with Aluminum Blades or Core. Some aluminum and stainless steel models may be constructed of all nonmagnetic components (no plastics) to meet MRI requirements. Consult your Titus representative for specific details. See individual model information for construction details. Titus reserves the right to make product improvements on a continual basis. As products are updated, new submittal sheets are published. Your Titus representative can provide you with updated technical information on all products.

50F / 50F-NT

50F

- Aluminum border
- ½ x ½ x ½" aluminum core
- High free area core
- Minimized pressure drop
- Matches general appearance of parabolic lighting fixtures
- MRI compatible

50R

- Steel border
- ½ x ½ x ½" aluminum core
- Can be used in fire-rated applications

50F-NT

- Same as 50F but designed to fit in Narrow Tee Ceiling Grids

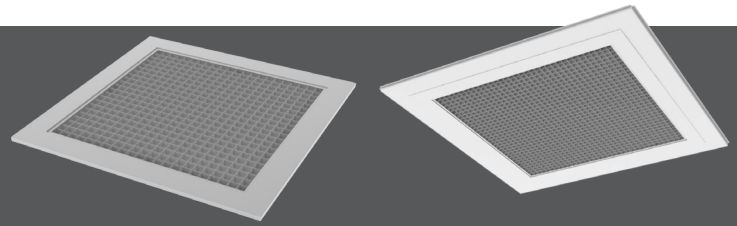

50F

50F-NT



metric sizes



MRI compatible

AVAILABLE MODELS:

- 50F / Aluminum Border & Core
- 50F-NT / Aluminum Border & Core / Narrow Tee
- 50R / Steel Border with Aluminum Core

FINISH

Standard Finish - #26 White

OVERVIEW

Titus Eggcrate grilles have the highest free area of any return grille. These grilles are available with aluminum border and aluminum grid; steel border and aluminum grid; or entirely stainless steel construction. Offered in ½ x ½ x ½", ½ x ½ x 1", or 1 x 1 x 1" core sizes. Also available as a filtered return.

PRODUCTS INCLUDE

- Standard Core
½ x ½ x ½ inch
- Optional Cores: (50F, 50F-NT)
½ x ½ x 1 inch
1 x 1 x 1 inch
- Countersunk Screw Holes
- #8 x 1¼" long Phillips Flat Head Sheet Metal Screws, Painted White
- Optional Border Types:
#1 - Surface Mount
#3 - Lay-In
#7 - Channel Frame (50F only)
#8 - Core Only (50F only)
- Optional Steel or Aluminum Opposed-Blade Damper



See website for Specifications

50F / 50F-NT DIMENSIONS

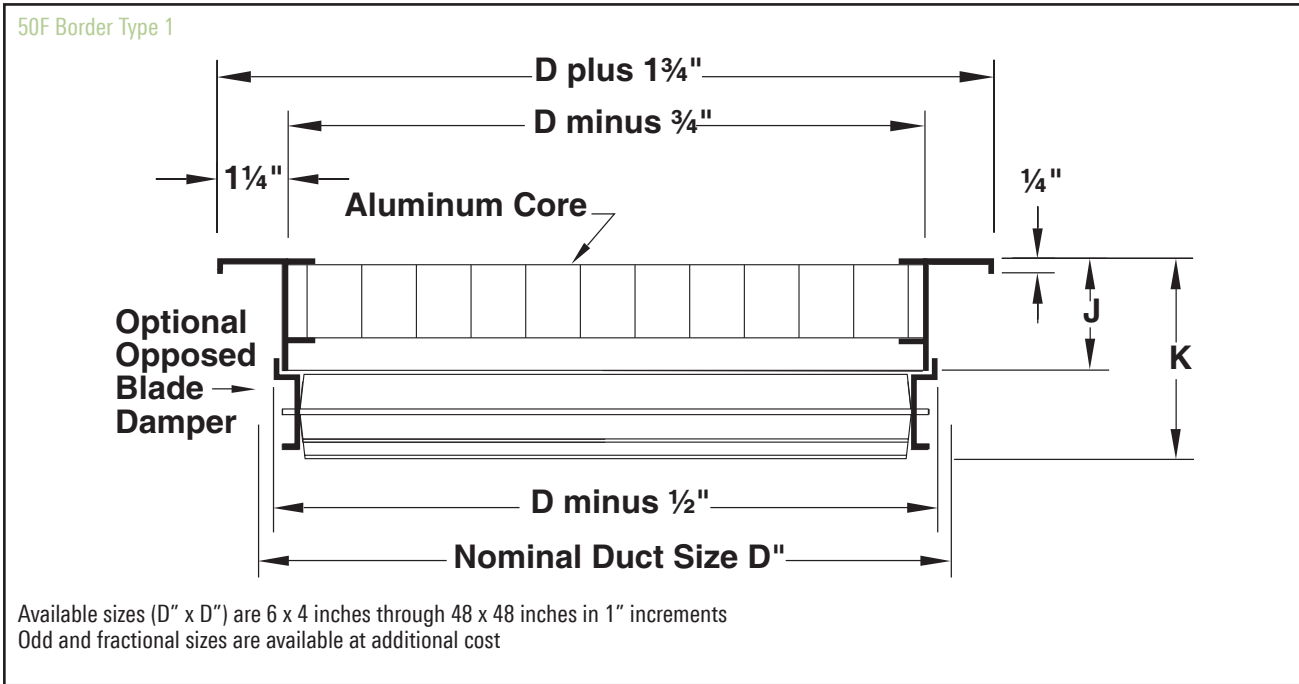

AVAILABLE SIZES

Model	Dimensions	Core Dimensions		
		1/2" x 1/2" x 1/2"	1/2" x 1/2" x 1"	1 x 1 x 1
50F	J	1 1/4	1	1
	K	2 1/2	2 15/16	2 15/16

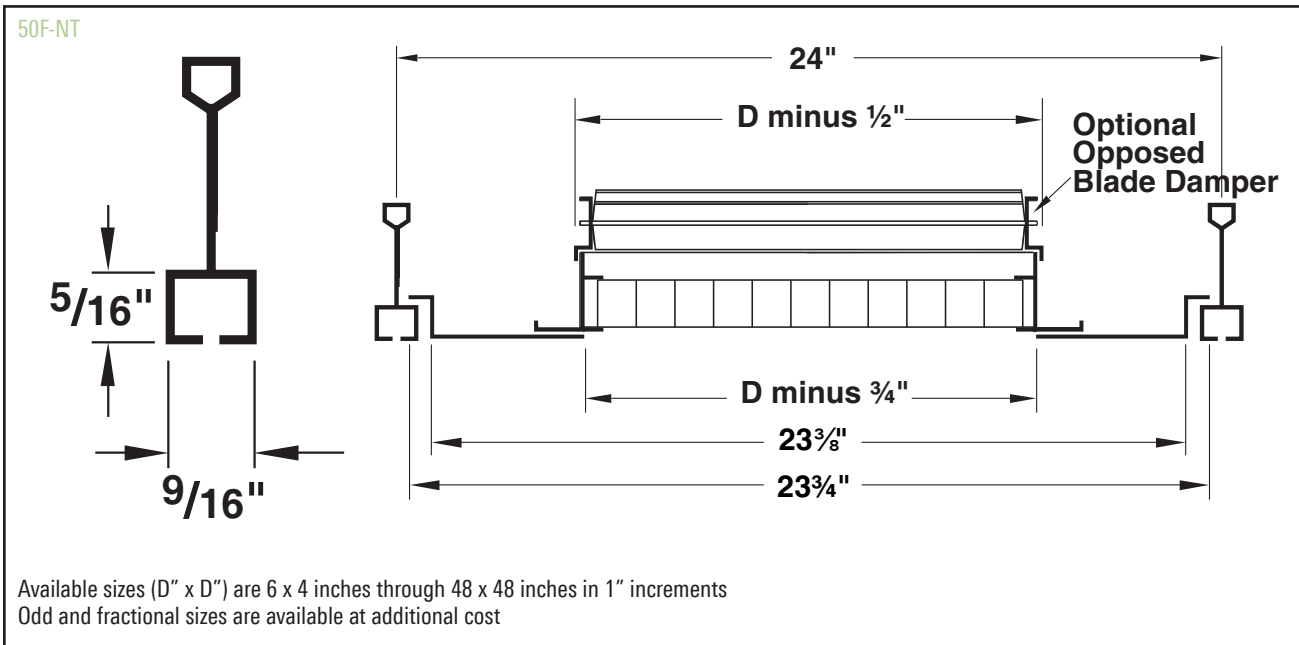

45F

45F

- Sight proof design
- Aluminum border
- ½ x ½ x ½" aluminum core
- 45° Deflection
- High free area core
- Matches general appearance of parabolic lighting fixtures
- MRI compatible

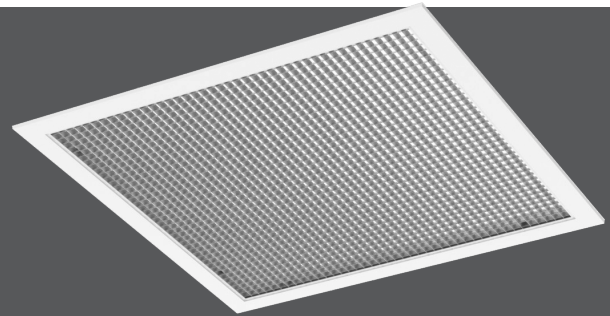

45F



metric sizes

sight proof design

MRI compatible

AVAILABLE MODEL:

45F / Aluminum Border & Core

FINISH

Standard Finish - #26 White

OVERVIEW

The 45F is an all aluminum return grille with an eggcrate core at a 45 degree deflection angle that prevents line of sight through the grille. Get the benefit of an attractive look which hides the plenum or the duct behind it without the use of a light shield or plenum.

For Performance Data, refer to page I24

PRODUCTS INCLUDE

- Standard Core
½ x ½ x ½ inch
- 45° Deflection
- Countersunk Screw Holes
- #8 x 1¼" long Phillips Flat Head Sheet Metal Screws, Painted White
- Optional Border Types:
#1 - Surface Mount
#3 - Lay-In
- Optional Steel or Aluminum Opposed-Blade Damper



See website for Specifications



Installation image of the 45F Eggcrate Return Grille installed in a gift shop

DIMENSIONS

45F DIMENSIONS

45F - Border Type 1 (Surface Mount)

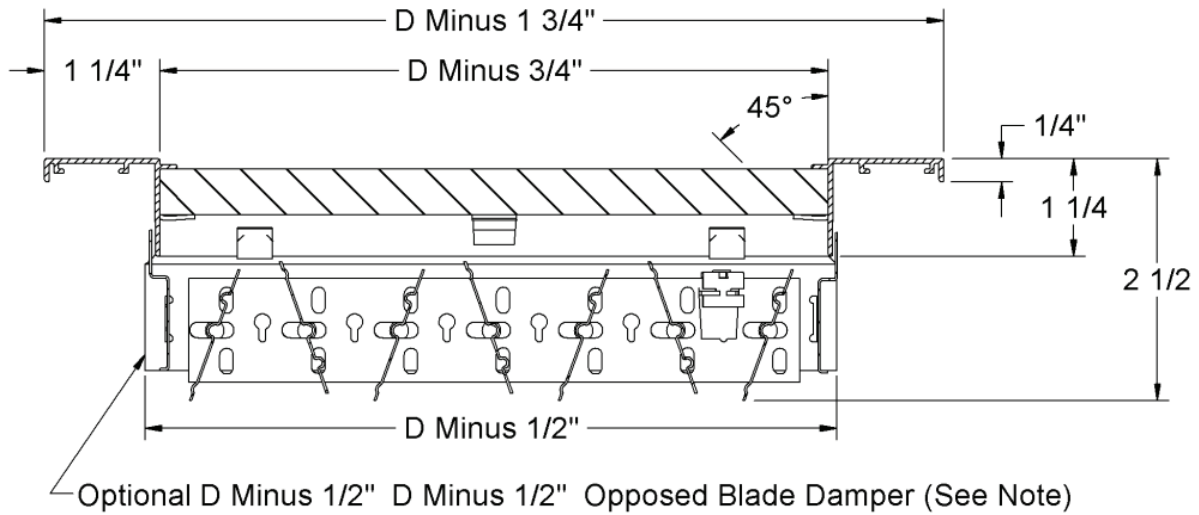

AVAILABLE SIZES (D" X D")

TYPE 1 SURFACE MOUNT FRAME				
NOMINAL SIZE	10 x 10	22 X 10	22 X 22	46 X 22

TYPE 3 LAY-IN FRAME	MODULE SIZE			
	12 X 12	24 X 12	24 X 24	48 X 24
NOMINAL SIZE(S)	10 X 10		10 X 10	10 X 10
		10 X 10	22 X 10	22 X 10
		22 X 10	22 X 10	22 X 22
			22 X 22	46 X 22

50R-SS

- Stainless steel border
- ½ x ½ x ½" stainless steel core
- High free area core
- Minimized pressure drop
- Matches general appearance of parabolic lighting fixtures
- Available in 304 Stainless Steel (standard) and 316 Stainless Steel (optional)

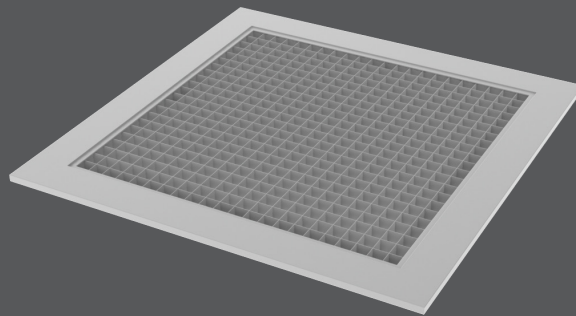

50R-SS

AVAILABLE MODEL:

50R-SS / Stainless Steel



See website for Specifications

FINISH

Standard Finish - #04 Mill

OVERVIEW

Titus Eggcrate grilles have the highest free area of any return grille. Available with aluminum border and aluminum grid; steel border and aluminum grid; or entirely stainless steel construction. Offered in ½ x ½ x ½", ½ x ½ x 1", or 1 x 1 x 1" core sizes. Also available as a filtered return.

OPTIONS

- Standard Core
½ x ½ x ½ inch
- Countersunk Screw Holes
- #8 x 1¼" long Phillips Flat Head Sheet
Metal Screws, Painted White
- Optional Steel or Aluminum Opposed-Blade Damper

50R-SS DIMENSIONS

50R-SS - Border Type 1

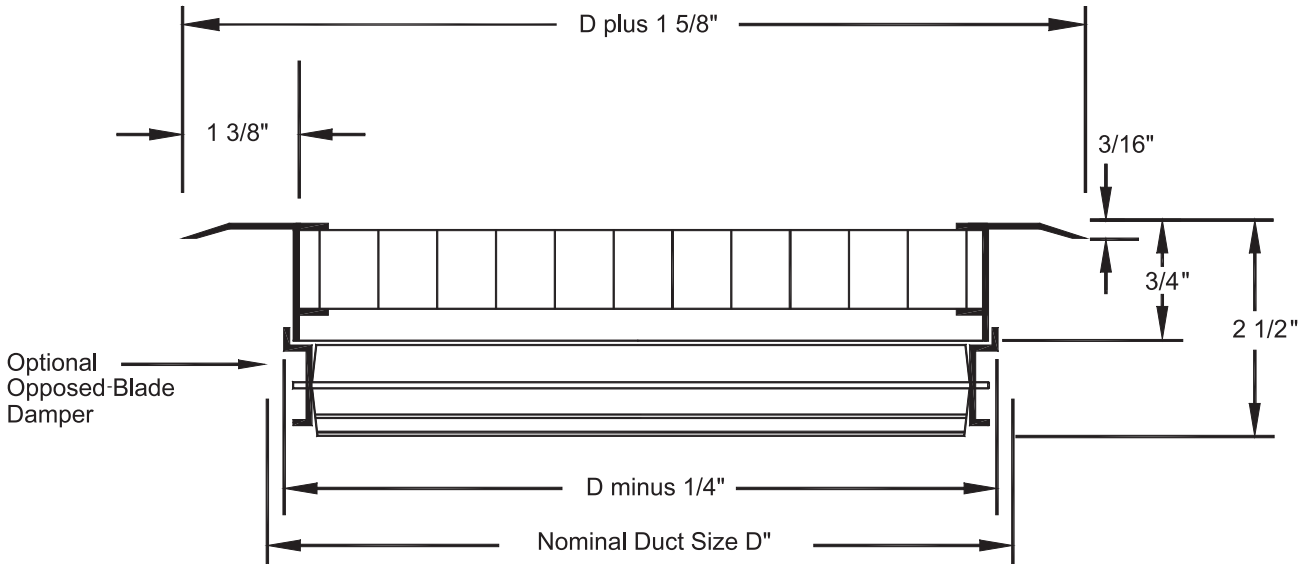

Available sizes (D" x D") are 6 x 4 inches through 48 x 48 inches in 1" increments
Odd and fractional sizes are available at additional cost

45R-SS

45R-SS

- Sight proof design
- Stainless steel border
- ½ x ½ x ½" stainless steel core
- 45° Deflection
- High free area core
- Matches general appearance of parabolic lighting fixtures
- MRI compatible

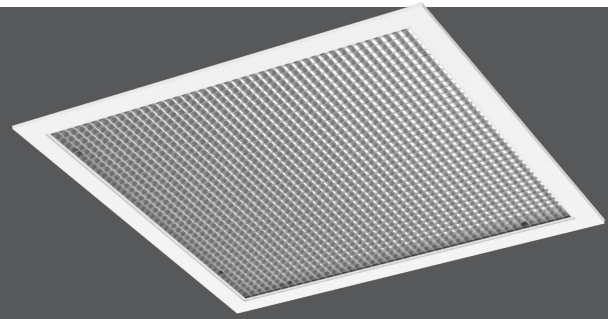

45R-SS



sight proof design MRI compatible



See website for Specifications

AVAILABLE MODEL:

45R-SS / Stainless Steel

FINISH

Standard Finish - #04 Mill

OVERVIEW

The 45R-SS is a stainless steel return grille with an eggcrate core at a 45 degree deflection angle that prevents line of sight through the grille. Get the benefit of an attractive look which hides the plenum or the duct behind it without the use of a light shield or plenum.

For Performance Data, refer to page I24

PRODUCTS INCLUDE

- Standard Core
½ x ½ x ½ inch
- 45° Deflection
- Countersunk Screw Holes
- #8 x 1¼" long Phillips Flat Head Sheet Metal Screws, Painted White
- Optional Border Types:
#1 - Surface Mount
#3 - Lay-In
- Optional Steel or Aluminum Opposed-Blade Damper

DIMENSIONS

45R-SS DIMENSIONS

45R-SS - Border Type 1 (Surface Mount)

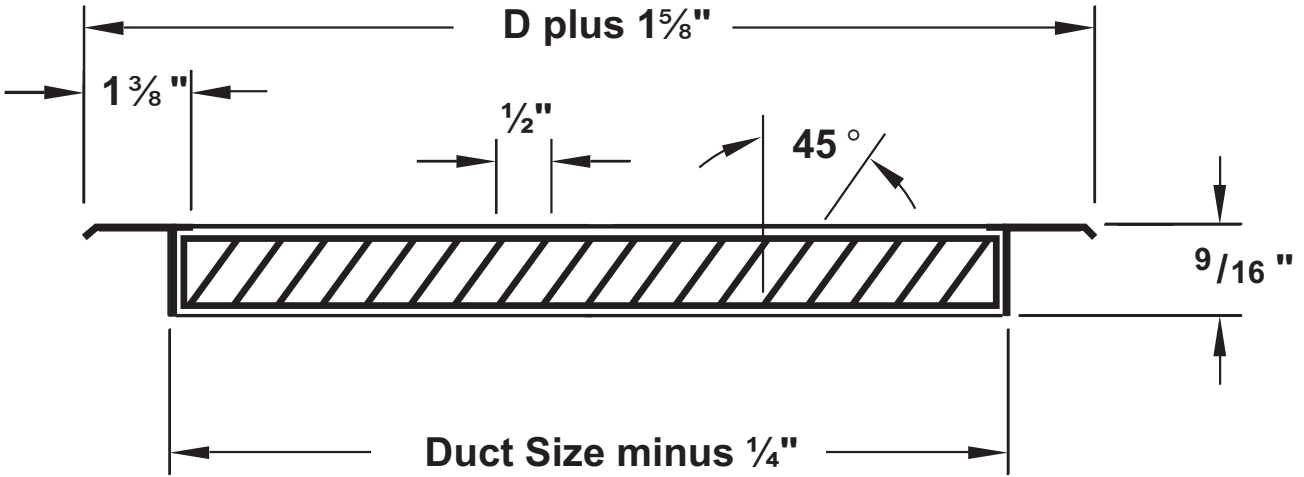

Available sizes (D" x D") are 6 x 4 inches through 48 x 48 inches in 1" increments
Odd and fractional sizes are available at additional cost

50FF

- Aluminum border and filter frame
- ½ x ½ x ½" aluminum core
- High free area core
- Minimized pressure drop
- Matches model 50F in appearance

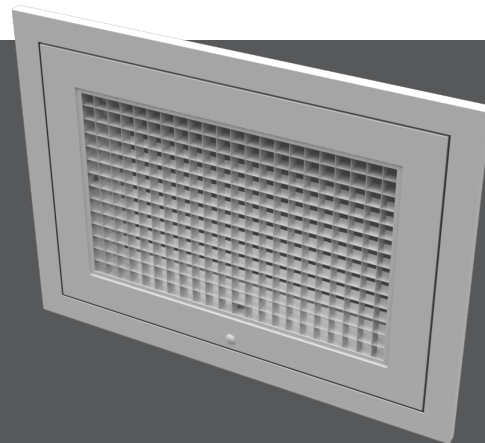

50FF

AVAILABLE MODEL:

50FF / Aluminum Border & Core / Filter Frame



See website for Specifications

FINISH

Standard Finish - #26 White

OVERVIEW

Filter Return

Titus Eggcrate grilles have the highest free area of any return grille. Available with aluminum border and aluminum grid; steel border and aluminum grid; or entirely stainless steel construction. Offered in ½ x ½ x ½", ½ x ½ x 1", or 1 x 1 x 1" core sizes. Also available as a filtered return.

For Performance Data, refer to page I22

OPTIONS

- ½ x ½ x ½" Aluminum Eggcrate Core
- 1 inch Filter Frame
- Available Border Types:
 - #1 - Surface Mount
 - #3 - Lay-In
- Hidden Screw Holes
- Filter by Others

DIMENSIONS

50FF DIMENSIONS

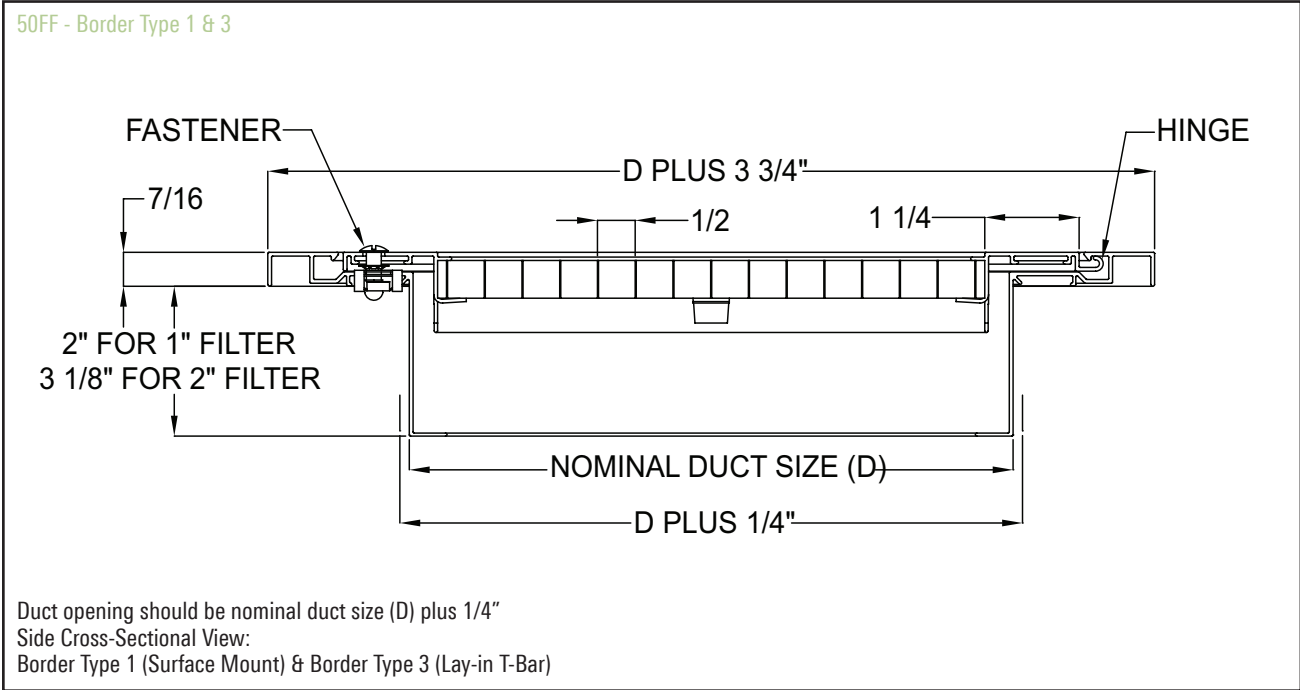

Please refer to page I85 for Hinge Locations

MODELS: 50F, 50F-NT, 50R, 50R-SS AND 50FF
PERFORMANCE BASED ON NOMINAL SIZES SHOWN IN BOLD

Nominal Duct Size (in.)	Nominal Duct Area sq. ft	Core Area sq. ft	Core Velocity Velocity Pressure 1x1x1 Neg. Ps ½x½x½ Neg. Ps	300		400		500		600		700		800		1000		1200		1400	
				0.006 0.013 0.013	0.01 0.024 0.024	0.016 0.037 0.037	0.022 0.054 0.053	0.031 0.073 0.073	0.04 0.096 0.095	0.062 0.15 0.148	0.09 0.216 0.213	0.122 0.294 0.29									
6x6	0.25	0.19	Airflow, cfm NC	57 -	76 -	95 -	114 10	133 17	152 22	190 31	228 39	266 45									
8x6	0.33	0.26	Airflow, cfm NC	78 -	104 -	130 -	156 10	182 17	208 22	260 31	312 39	364 45									
10x6	0.42	0.34	Airflow, cfm NC	102 -	136 -	170 -	204 11	238 17	272 23	340 32	408 39	476 46									
8x8	0.44	0.37	Airflow, cfm NC	111 -	148 -	185 -	222 11	259 17	296 23	370 32	444 39	518 46									
12x6	0.50	0.41	Airflow, cfm NC	123 -	164 -	205 -	246 11	287 18	328 23	410 32	492 40	574 46									
14x6	0.58	0.48	Airflow, cfm NC	144 -	192 -	240 -	288 11	336 18	384 23	480 32	576 40	672 46									
16x6 12x8	0.67	0.57	Airflow, cfm NC	171 -	228 -	285 -	342 12	399 18	456 23	570 32	684 40	798 46									
10x10	0.69	0.59	Airflow, cfm NC	177 -	236 -	295 -	354 12	413 18	472 23	590 33	708 40	826 46									
18x6	0.75	0.63	Airflow, cfm NC	189 -	252 -	315 -	378 12	441 18	504 24	630 33	756 40	882 46									
20x6 12x10	0.83	0.72	Airflow, cfm NC	216 -	288 -	360 -	432 12	504 18	576 24	720 33	864 40	1008 46									
22x6	0.92	0.77	Airflow, cfm NC	231 -	308 -	385 -	462 12	539 18	616 24	770 33	924 40	1078 47									
24x6 12x12	1.00	0.88	Airflow, cfm NC	264 -	352 -	440 -	528 12	616 18	704 24	880 33	1056 40	1232 47									
30x6 18x10	1.25	1.11	Airflow, cfm NC	333 -	444 -	555 -	666 13	777 19	888 24	1110 34	1332 41	1554 47									
14x14	1.36	1.22	Airflow, cfm NC	366 -	488 -	610 -	732 13	854 19	976 24	1220 34	1464 41	1708 47									
36x6 18x12	1.50	1.35	Airflow, cfm NC	405 -	540 -	675 -	810 13	945 19	1080 24	1350 34	1620 41	1890 47									
22x10	1.53	1.37	Airflow, cfm NC	411 -	548 -	685 -	822 13	959 19	1096 25	1370 34	1644 41	1918 47									
30x8 24x10	1.67	1.49	Airflow, cfm NC	447 -	596 -	745 -	894 13	1043 19	1192 25	1490 34	1788 41	2086 47									
42x6 18x14	1.75	1.59	Airflow, cfm NC	477 -	636 -	795 -	954 13	1113 19	1272 25	1590 34	1908 41	2226 47									
16x16	1.78	1.62	Airflow, cfm NC	486 -	648 -	810 -	972 13	1134 19	1296 25	1620 34	1944 41	2268 48									
24x12 18x16	2.00	1.82	Airflow, cfm NC	546 -	728 -	910 -	1092 13	1274 19	1456 25	1820 34	2184 41	2548 48									
18x18	2.25	2.07	Airflow, cfm NC	621 -	828 -	1035 -	1242 13	1449 19	1656 25	2070 34	2484 41	2898 48									
24x14	2.33	2.14	Airflow, cfm NC	642 -	856 -	1070 -	1284 13	1498 20	1712 25	2140 34	2568 42	2996 48									
30x12	2.50	2.29	Airflow, cfm NC	687 -	916 -	1145 -	1374 13	1603 20	1832 25	2290 34	2748 42	3206 48									
24x16	2.67	2.46	Airflow, cfm NC	738 -	984 -	1230 -	1476 13	1722 20	1968 25	2460 34	2952 42	3444 48									
20x20	2.78	2.57	Airflow, cfm NC	771 -	1028 -	1285 -	1542 13	1799 20	2056 25	2570 34	3084 42	3598 48									
36x12	3.00	2.75	Airflow, cfm NC	825 -	1100 -	1375 -	1650 14	1925 20	2200 25	2750 34	3300 42	3850 48									
30x16 24x20	3.33	3.11	Airflow, cfm NC	933 -	1244 -	1555 -	1866 14	2177 20	2488 25	3110 35	3732 42	4354 48									
22x22	3.36	3.14	Airflow, cfm NC	942 -	1256 -	1570 -	1884 14	2198 20	2512 25	3140 35	3768 42	4396 48									
42x12 36x14	3.50	3.22	Airflow, cfm NC	966 -	1288 -	1610 -	1932 14	2254 20	2576 26	3220 35	3864 42	4508 48									
24x22	3.67	3.43	Airflow, cfm NC	1029 -	1372 -	1715 -	2058 14	2401 20	2744 26	3430 35	4116 42	4802 48									
30x18	3.75	3.50	Airflow, cfm NC	1050 -	1400 -	1750 -	2100 14	2450 20	2800 26	3500 35	4200 42	4900 48									

• Static pressures are negative, in inches of water, measured per ANSI/ASHRAE Standard 70-2006

• NC based on room absorption of 10dB, re 10⁻¹² watts, measured per ANSI/ASHRAE Standard 70-2006

MODELS: 50F, 50F-NT, 50R, 50R-SS AND 50FF
PERFORMANCE BASED ON NOMINAL SIZES SHOWN IN BOLD

Nominal Duct Size (in.)	Nominal Duct Area sq. ft	Core Area sq. ft	Core Velocity 1x1x1 Neg. Ps ½x½x½ Neg. Ps	NC 20 NC 30 NC 40											
				300 0.006 0.013 0.013	400 0.01 0.024 0.024	500 0.016 0.037 0.037	600 0.022 0.054 0.053	700 0.031 0.073 0.073	800 0.04 0.096 0.095	1000 0.062 0.15 0.148	1200 0.09 0.216 0.213	1400 0.122 0.294 0.29			
48x12 24x24	4.00	3.75	Airflow, cfm NC	1125 -	1500 -	1875 -	2250 14	2625 20	3000 26	3750 35	4500 42	5250 49			
36x18	4.50	4.22	Airflow, cfm NC	1266 -	1688 -	2110 -	2532 14	2954 20	3376 26	4220 35	5064 42	5908 49			
36x20 30x24	5.00	4.71	Airflow, cfm NC	1413 -	1884 -	2355 -	2826 14	3297 21	3768 26	4710 35	5652 43	6594 49			
42x18	5.25	4.94	Airflow, cfm NC	1482 -	1976 -	2470 -	2964 14	3458 21	3952 26	4940 35	5928 43	6916 49			
28x28	5.44	5.16	Airflow, cfm NC	1548 -	2064 -	2580 -	3096 14	3612 21	4128 26	5160 35	6192 43	7224 49			
42x20 30x28	5.83	5.51	Airflow, cfm NC	1653 -	2204 -	2755 -	3306 14	3857 21	4408 26	5510 35	6612 43	7714 49			
48x18 36x24	6.00	5.66	Airflow, cfm NC	1698 -	2264 -	2830 -	3396 14	3962 21	4528 26	5660 35	6792 43	7924 49			
30x30	6.25	5.94	Airflow, cfm NC	1782 -	2376 -	2970 -	3564 15	4158 21	4752 26	5940 35	7128 43	8316 49			
42x24 36x28	7.00	6.66	Airflow, cfm NC	1998 -	2664 -	3330 -	3996 15	4662 21	5328 26	6660 36	7992 43	9324 49			
46x22	7.03	6.68	Airflow, cfm NC	2004 -	2672 -	3340 -	4008 15	4676 21	5344 26	6680 36	8016 43	9352 49			
32x32	7.11	6.78	Airflow, cfm NC	2034 -	2712 -	3390 -	4068 15	4746 21	5424 27	6780 36	8136 43	9492 49			
36x30	7.50	7.16	Airflow, cfm NC	2148 -	2864 -	3580 -	4296 15	5012 21	5728 27	7160 36	8592 43	10024 49			
48x24 36x32	8.00	7.63	Airflow, cfm NC	2289 -	3052 -	3815 -	4578 15	5341 21	6104 27	7630 36	9156 43	10682 49			
34x34	8.03	7.68	Airflow, cfm NC	2304 -	3072 -	3840 -	4608 15	5376 21	6144 27	7680 36	9216 43	10752 49			
36x34	8.50	8.14	Airflow, cfm NC	2442 -	3256 -	4070 -	4884 15	5698 21	6512 27	8140 36	9768 43	11396 50			
42x30	8.75	8.38	Airflow, cfm NC	2514 -	3352 -	4190 -	5028 15	5866 21	6704 27	8380 36	10056 43	11732 50			
36x36	9.00	8.63	Airflow, cfm NC	2589 -	3452 -	4315 -	5178 15	6041 21	6904 27	8630 36	10356 43	12082 50			
42x34 48x30	10.00	9.60	Airflow, cfm NC	2880 -	3840 -	4800 -	5760 15	6720 21	7680 27	9600 36	11520 43	13440 50			
38x38	10.03	9.64	Airflow, cfm NC	2892 -	3856 -	4820 -	5784 15	6748 21	7712 27	9640 36	11568 43	13496 50			
42x36	10.50	10.10	Airflow, cfm NC	3030 -	4040 -	5050 -	6060 15	7070 22	8080 27	10100 36	12120 44	14140 50			
46x34	10.86	10.45	Airflow, cfm NC	3135 -	4180 -	5225 -	6270 15	7315 22	8360 27	10450 36	12540 44	14630 50			
42x38	11.08	10.67	Airflow, cfm NC	3201 -	4268 -	5335 -	6402 15	7469 22	8536 27	10670 36	12804 44	14938 50			
40x40	11.11	10.70	Airflow, cfm NC	3210 -	4280 -	5350 -	6420 15	7490 22	8560 27	10700 36	12840 44	14980 50			
48x36	12.00	11.57	Airflow, cfm NC	3471 -	4628 -	5785 -	6942 15	8099 22	9256 27	11570 36	13884 44	16198 50			
42x42	12.25	11.82	Airflow, cfm NC	3546 -	4728 -	5910 -	7092 15	8274 22	9456 27	11820 36	14184 44	16548 50			
44x44	13.44	12.99	Airflow, cfm NC	3897 -	5196 -	6495 -	7794 16	9093 22	10392 27	12990 36	15588 44	18186 50			
48x42	14.00	13.54	Airflow, cfm NC	4062 -	5416 -	6770 -	8124 16	9478 22	10832 27	13540 37	16248 44	18956 50			
46x46	14.69	14.22	Airflow, cfm NC	4266 -	5688 -	7110 -	8532 16	9954 22	11376 27	14220 37	17064 44	19908 50			
48x46	15.33	14.85	Airflow, cfm NC	4455 -	5940 -	7425 -	8910 16	10395 22	11880 27	14850 37	17820 44	20790 50			
48x48	16.00	15.50	Airflow, cfm NC	4650 -	6200 -	7750 -	9300 16	10850 22	12400 28	15500 37	18600 44	21700 50			

• Static pressures are negative, in inches of water, measured per ANSI/ASHRAE Standard 70-2006

• NC based on room absorption of 10dB, re 10⁻¹² watts, measured per ANSI/ASHRAE Standard 70-2006

MODELS: 45F / 45R-SS

Nominal Duct Size (inches)	Nominal Duct Area (Sq. Ft.)	Core Area (Sq. Ft.)	Core Velocity Velocity Pressure ½ x ½ x ½ Neg. Ps.	200	250	300	350	400	450	500	550	600	650
				0.002	0.004	0.006	0.008	0.010	0.013	0.016	0.019	0.022	0.026
				0.016	0.025	0.037	0.05	0.065	0.082	0.102	0.123	0.146	0.172
6 x 6	0.25	0.19	Airflow, cfm	50	63	75	88	100	113	125	138	150	163
			NC	-	-	15	19	22	26	28	31	33	35
8 x 8	0.44	0.34	Airflow, cfm	89	111	133	156	178	200	222	244	267	289
			NC	-	-	15	19	23	26	29	32	34	36
10 x 10	0.69	0.53	Airflow, cfm	139	174	208	243	278	313	347	382	417	451
			NC	-	-	16	20	24	27	30	33	35	37
12 x 12	1.00	0.76	Airflow, cfm	200	250	300	350	400	450	500	550	600	650
			NC	-	-	17	21	25	28	31	34	36	38
14 x 14	1.36	1.03	Airflow, cfm	272	340	408	476	544	613	681	749	817	885
			NC	-	-	17	22	26	29	32	35	38	40
10 x 22	1.53	1.16	Airflow, cfm	306	382	458	535	611	688	764	840	917	993
			NC	-	-	18	22	26	30	33	36	38	41
16 x 16	1.78	1.35	Airflow, cfm	356	444	533	622	711	800	889	978	1067	1156
			NC	-	-	18	23	27	30	34	36	39	41
18 x 18	2.25	1.71	Airflow, cfm	450	563	675	788	900	1013	1125	1238	1350	1463
			NC	-	-	19	24	28	32	35	38	41	43
20 x 20	2.78	2.11	Airflow, cfm	556	694	833	972	1111	1250	1389	1528	1667	1806
			NC	-	15	20	25	29	33	36	39	42	45
22 x 22	3.36	2.55	Airflow, cfm	672	840	1008	1176	1344	1513	1681	1849	2017	2185
			NC	-	16	22	27	31	34	38	41	43	46
30 x 18	3.75	2.85	Airflow, cfm	750	938	1125	1313	1500	1688	1875	2063	2250	2438
			NC	-	17	23	27	32	35	39	42	44	47
36 x 20	5.00	3.80	Airflow, cfm	1000	1250	1500	1750	2000	2250	2500	2750	3000	3250
			NC	-	20	25	30	34	38	41	44	46	49
42 x 20	5.83	4.43	Airflow, cfm	1167	1458	1750	2042	2333	2625	2917	3208	3500	3792
			NC	16	22	27	32	35	39	42	44	47	49
30 x 30	6.25	4.75	Airflow, cfm	1250	1563	1875	2188	2500	2813	3125	3438	3750	4063
			NC	18	24	28	33	36	39	42	45	47	49
46 x 22	7.03	5.34	Airflow, cfm	1406	1757	2108	2460	2811	3163	3514	3865	4217	4568
			NC	21	26	30	34	37	40	42	45	47	49

AVAILABLE SIZES (D" X D")

TYPE 1 SURFACE MOUNT FRAME				
NOMINAL SIZE	10 x 10	22 X 10	22 X 22	46 X 22

TYPE 3 LAY-IN FRAME	MODULE SIZE				
	12 X 12	24 X 12	24 X 24	48 X 24	
NOMINAL SIZE(S)	10 X 10		10 X 10	10 X 10	
		10 X 10		22 X 10	
		22 X 10	22 X 10	22 X 22	
			22 X 22	46 X 22	

Perforated Return Grilles

specialized grilles

8F / 8FF / 8R / 8RF / 8SS

8F, 8R, 8SS

- Perforated screen with $\frac{3}{16}$ " diameter holes on $\frac{1}{4}$ inch staggered centers
- 51% free area perforated face
- Matches general appearance of industry standard perforated diffusers

8FF, 8RF

- Available for lay-in or surface mounting applications
- For use with 1" thick filters
- Perforated screen with $\frac{3}{16}$ " diameter holes on $\frac{1}{4}$ inch staggered centers
- Matches general appearance of industry standard perforated diffusers

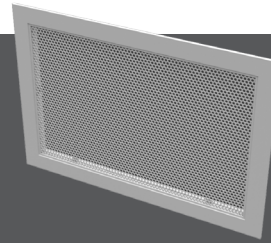

8F / 8R / 8SS

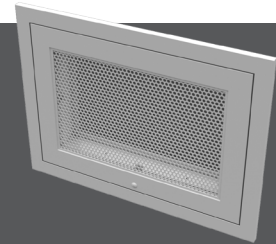

8FF / 8RF



metric sizes

AVAILABLE MODELS:

8F / Aluminum
8R / Steel
8SS / 304 Stainless Steel
8FF / Aluminum Filter Grille
8RF / Steel Filter Grille

FINISHES

Standard Finish - #26 White (8F, 8R, 8FF, 8RF)
Standard Finish - #04 Mill (8SS)

OVERVIEW

Perforated return grilles have a standard 51 percent free area on the face and can be used as a matching return in conjunction with perforated supply diffusers. Additional options include a filter frame and steel, aluminum or stainless steel construction.

PRODUCTS INCLUDE

- Available Border Types:
 - #1 - Surface Mount (All models)
 - #2 - Snap-In (8F)
 - #3 - Lay-In (8F, 8R, 8RF, 8FF)
 - #4 - Spline (8F)
- Countersunk Screw Holes
- Optional Steel Opposed-Blade Damper



See website for Specifications

DIMENSIONS

Redefine your comfort zone™ | www.titus-hvac.com

8F, 8R, 8FF, 8RF, DIMENSIONS

8F, 8R - Border Type 1

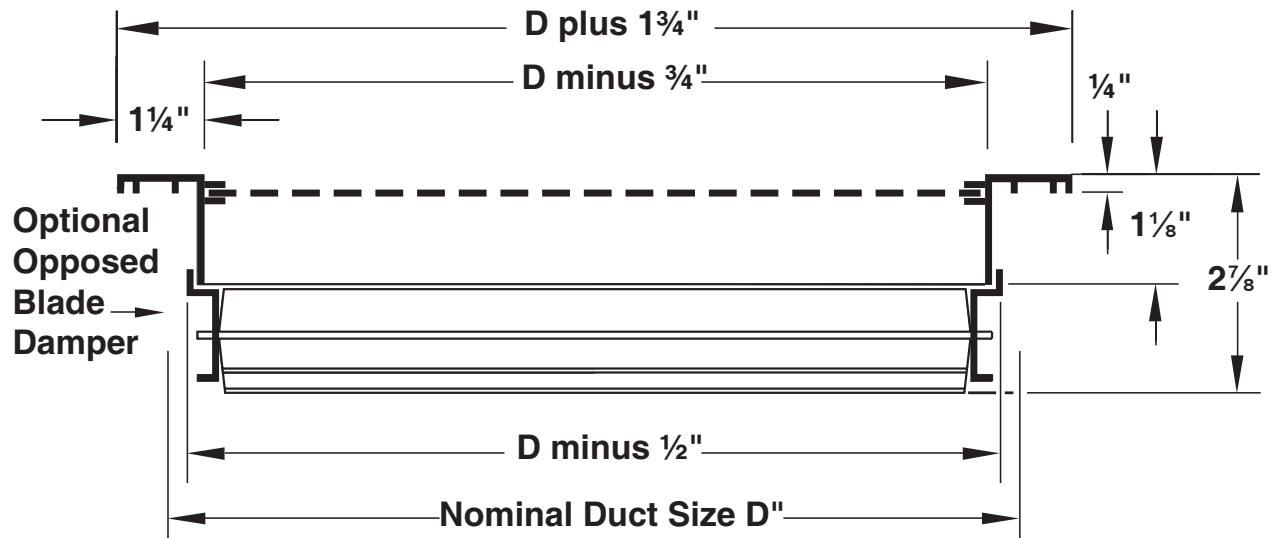

Available sizes ($D" \times D"$) Border Type 1 are 6 x 4 inches through 48 x 48 inches in 2" increments. Odd and fractional sizes are available at additional cost.

8FF, 8RF - Border Type 1 & 3

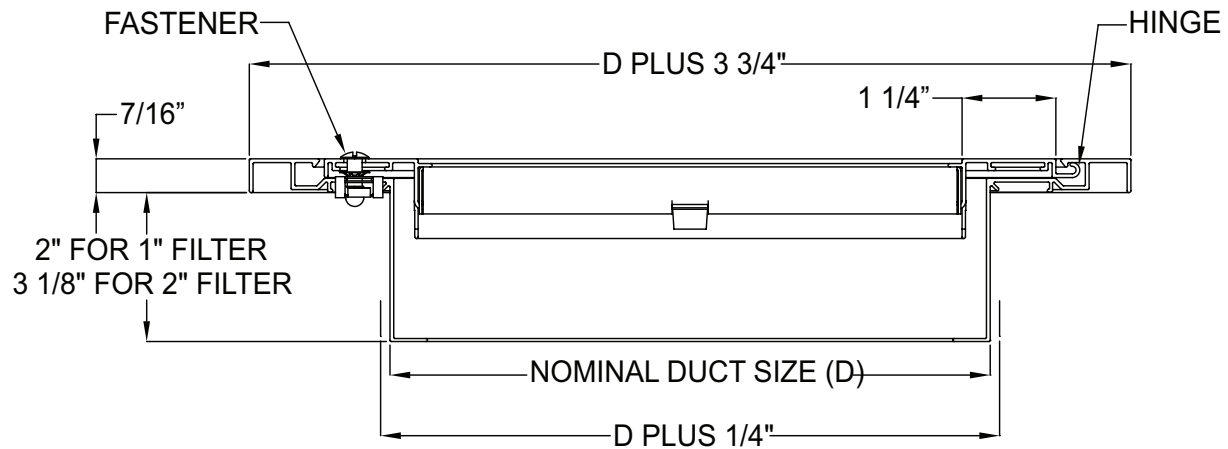

Duct opening should be nominal duct size (D) plus $\frac{1}{4}"$
Side Cross-Sectional View:
Border Type 1 (Surface Mount) & Border Type 3 (Lay-in T-Bar)

Please refer to page I85 for Hinge Locations

MODELS: 8F, 8FF, 8R, 8RF, AND 8SS
PERFORMANCE BASED ON NOMINAL SIZES SHOWN IN BOLD

Nominal Duct Size (in.)	Nominal Duct Area sq. ft	Core Area sq. ft	Core Velocity Velocity Pressure Neg. Static Pressure	NC 10				NC 20		NC 30		NC 40
				300 0.010 0.051	400 0.016 0.079	500 0.022 0.114	600 0.031 0.156	700 0.040 0.203	800 0.062 0.318	1000 0.090 0.458	1200 0.122 0.623	1400 0.12 0.62
6x6	0.25	0.19	Airflow, cfm NC	57 -	76 -	95 -	114 -	133 13	152 16	190 21	228 26	266 30
8x6	0.33	0.26	Airflow, cfm NC	78 -	104 -	130 -	156 -	182 14	208 17	260 23	312 27	364 31
10x6	0.42	0.34	Airflow, cfm NC	102 -	136 -	170 -	204 11	238 15	272 18	340 24	408 28	476 32
8x8	0.44	0.37	Airflow, cfm NC	111 -	148 -	185 -	222 12	259 15	296 19	370 24	444 29	518 33
12x6	0.5	0.41	Airflow, cfm NC	123 -	164 -	205 -	246 12	287 16	328 19	410 25	492 29	574 33
14x6	0.58	0.48	Airflow, cfm NC	144 -	192 -	240 -	288 13	336 17	384 20	480 25	576 30	672 34
16x6 12x8	0.67	0.57	Airflow, cfm NC	171 -	228 -	285 -	342 14	399 17	456 21	570 26	684 31	798 34
10x10	0.69	0.59	Airflow, cfm NC	177 -	236 -	295 -	354 14	413 18	472 21	590 26	708 31	826 35
18x6	0.75	0.63	Airflow, cfm NC	189 -	252 -	315 -	378 14	441 18	504 21	630 27	756 31	882 35
20x6 12x10	0.83	0.72	Airflow, cfm NC	216 -	288 -	360 -	432 15	504 18	576 22	720 27	864 32	1008 35
22x6	0.92	0.77	Airflow, cfm NC	231 -	308 -	385 -	462 15	539 19	616 22	770 27	924 32	1078 36
24x6 12x12	1	0.88	Airflow, cfm NC	264 -	352 -	440 11	528 15	616 19	704 23	880 28	1056 32	1232 36
30x6 18x10	1.25	1.11	Airflow, cfm NC	333 -	444 -	555 12	666 16	777 20	888 24	1110 29	1332 33	1554 37
14x14	1.36	1.22	Airflow, cfm NC	366 -	488 -	610 12	732 17	854 21	976 24	1220 29	1464 34	1708 38
36x6 18x12	1.5	1.35	Airflow, cfm NC	405 -	540 -	675 13	810 17	945 21	1080 24	1350 30	1620 34	1890 38
22x10	1.53	1.37	Airflow, cfm NC	411 -	548 -	685 13	822 17	959 21	1096 24	1370 30	1644 34	1918 38
30x8 24x10	1.67	1.49	Airflow, cfm NC	447 -	596 -	745 13	894 18	1043 22	1192 25	1490 30	1788 35	2086 39
42x6 18x14	1.75	1.59	Airflow, cfm NC	477 -	636 -	795 14	954 18	1113 22	1272 25	1590 31	1908 35	2226 39
16x16	1.78	1.62	Airflow, cfm NC	486 -	648 -	810 14	972 18	1134 22	1296 25	1620 31	1944 35	2268 39
24x12 18x16	2	1.82	Airflow, cfm NC	546 -	728 -	910 14	1092 19	1274 22	1456 26	1820 31	2184 36	2548 39
18x18	2.25	2.07	Airflow, cfm NC	621 -	828 -	1035 15	1242 19	1449 23	1656 26	2070 32	2484 36	2898 40
24x14	2.33	2.14	Airflow, cfm NC	642 -	856 -	1070 15	1284 19	1498 23	1712 26	2140 32	2568 36	2996 40
30x12	2.5	2.29	Airflow, cfm NC	687 -	916 -	1145 15	1374 20	1603 23	1832 27	2290 32	2748 37	3206 40
24x16	2.67	2.46	Airflow, cfm NC	738 -	984 -	1230 15	1476 20	1722 24	1968 27	2460 32	2952 37	3444 41
20x20	2.78	2.57	Airflow, cfm NC	771 -	1028 -	1285 16	1542 20	1799 24	2056 27	2570 33	3084 37	3598 41
36x12	3	2.75	Airflow, cfm NC	825 -	1100 -	1375 16	1650 20	1925 24	2200 27	2750 33	3300 37	3850 41
30x16 24x20	3.33	3.11	Airflow, cfm NC	933 -	1244 11	1555 16	1866 21	2177 25	2488 28	3110 33	3732 38	4354 42
22x22	3.36	3.14	Airflow, cfm NC	942 -	1256 11	1570 17	1884 21	2198 25	2512 28	3140 34	3768 38	4396 42
42x12 36x14	3.5	3.22	Airflow, cfm NC	966 -	1288 11	1610 17	1932 21	2254 25	2576 28	3220 34	3864 38	4508 42
24x22	3.67	3.43	Airflow, cfm NC	1029 -	1372 11	1715 17	2058 21	2401 25	2744 28	3430 34	4116 38	4802 42
30x18	3.75	3.5	Airflow, cfm NC	1050 -	1400 12	1750 17	2100 21	2450 25	2800 29	3500 34	4200 38	4900 42

• Static pressures are negative, in inches of water, measured per ANSI/ASHRAE Standard 70-2006

• NC based on room absorption of 10dB, re 10⁻¹² watts, measured per ANSI/ASHRAE Standard 70-2006

MODELS: 8F, 8FF, 8R, 8RF, AND 8SS
PERFORMANCE BASED ON NOMINAL SIZES SHOWN IN BOLD

Nominal Duct Size (in.)	Nominal Duct Area sq. ft	Core Area sq. ft	Core Velocity Velocity Pressure Neg. Static Pressure	NC 10		NC 20		NC 30		NC 40		
				300 0.006 0.029	400 0.010 0.051	500 0.016 0.079	600 0.022 0.114	700 0.031 0.156	800 0.040 0.203	1000 0.062 0.318	1200 0.090 0.458	1400 0.122 0.623
48x12 24x24	4.00	3.75	Airflow, cfm NC	1125 -	1500 12	1875 17	2250 22	2625 26	3000 29	3750 34	4500 39	5250 43
36x18	4.50	4.22	Airflow, cfm NC	1266 -	1688 12	2110 18	2532 22	2954 26	3376 29	4220 35	5064 39	5908 43
36x20 30x24	5.00	4.71	Airflow, cfm NC	1413 -	1884 13	2355 18	2826 23	3297 27	3768 30	4710 35	5652 40	6594 44
42x18	5.25	4.94	Airflow, cfm NC	1482 -	1976 13	2470 18	2964 23	3458 27	3952 30	4940 36	5928 40	6916 44
28x28	5.44	5.16	Airflow, cfm NC	1548 -	2064 13	2580 19	3096 23	3612 27	4128 30	5160 36	6192 40	7224 44
42x20 30x28	5.83	5.51	Airflow, cfm NC	1653 -	2204 13	2755 19	3306 23	3857 27	4408 30	5510 36	6612 40	7714 44
48x18 36x24	6.00	5.66	Airflow, cfm NC	1698 -	2264 14	2830 19	3396 24	3962 27	4528 31	5660 36	6792 41	7924 44
30x30	6.25	5.94	Airflow, cfm NC	1782 -	2376 14	2970 19	3564 24	4158 28	4752 31	5940 36	7128 41	8316 45
42x24 36x28	7.00	6.66	Airflow, cfm NC	1998 -	2664 14	3330 20	3996 24	4662 28	5328 31	6660 37	7992 41	9324 45
46x22	7.03	6.68	Airflow, cfm NC	2004 -	2672 14	3340 20	4008 24	4676 28	5344 31	6680 37	8016 41	9352 45
32x32	7.11	6.78	Airflow, cfm NC	2034 -	2712 14	3390 20	4068 24	4746 28	5424 31	6780 37	8136 41	9492 45
36x30	7.50	7.16	Airflow, cfm NC	2148 -	2864 15	3580 20	4296 25	5012 28	5728 32	7160 37	8592 42	10024 45
48x24 36x32	8.00	7.63	Airflow, cfm NC	2289 -	3052 15	3815 20	4578 25	5341 29	6104 32	7630 37	9156 42	10682 46
34x34	8.03	7.68	Airflow, cfm NC	2304 -	3072 15	3840 20	4608 25	5376 29	6144 32	7680 37	9216 42	10752 46
36x34	8.50	8.14	Airflow, cfm NC	2442 -	3256 15	4070 21	4884 25	5698 29	6512 32	8140 38	9768 42	11396 46
42x30	8.75	8.38	Airflow, cfm NC	2514 -	3352 15	4190 21	5028 25	5866 29	6704 32	8380 38	10056 42	11732 46
36x36	9.00	8.63	Airflow, cfm NC	2589 -	3452 15	4315 21	5178 25	6041 29	6904 32	8630 38	10356 42	12082 46
42x34 48x30	10.00	9.60	Airflow, cfm NC	2880 -	3840 16	4800 21	5760 26	6720 30	7680 33	9600 38	11520 43	13440 47
38x38	10.03	9.64	Airflow, cfm NC	2892 -	3856 16	4820 21	5784 26	6748 30	7712 33	9640 38	11568 43	13496 47
42x36	10.50	10.10	Airflow, cfm NC	3030 -	4040 16	5050 22	6060 26	7070 30	8080 33	10100 39	12120 43	14140 47
46x34	10.86	10.45	Airflow, cfm NC	3135 -	4180 16	5225 22	6270 26	7315 30	8360 33	10450 39	12540 43	14630 47
42x38	11.08	10.67	Airflow, cfm NC	3201 -	4268 16	5335 22	6402 26	7469 30	8536 33	10670 39	12804 43	14938 47
40x40	11.11	10.70	Airflow, cfm NC	3210 -	4280 16	5350 22	6420 26	7490 30	8560 33	10700 39	12840 43	14980 47
48x36	12.00	11.57	Airflow, cfm NC	3471 -	4628 17	5785 22	6942 27	8099 30	9256 34	11570 39	13884 44	16198 47
42x42	12.25	11.82	Airflow, cfm NC	3546 -	4728 17	5910 22	7092 27	8274 31	9456 34	11820 39	14184 44	16548 48
44x44	13.44	12.99	Airflow, cfm NC	3897 -	5196 17	6495 23	7794 27	9093 31	10392 34	12990 40	15588 44	18186 48
48x42	14.00	13.54	Airflow, cfm NC	4062 -	5416 17	6770 23	8124 27	9478 31	10832 34	13540 40	16248 44	18956 48
46x46	14.69	14.22	Airflow, cfm NC	4266 11	5688 18	7110 23	8532 28	9954 31	11376 35	14220 40	17064 45	19908 48
48x46	15.33	14.85	Airflow, cfm NC	4455 11	5940 18	7425 23	8910 28	10395 32	11880 35	14850 40	17820 45	20790 49
48x48	16.00	15.50	Airflow, cfm NC	4650 11	6200 18	7750 23	9300 28	10850 32	12400 35	15500 40	18600 45	21700 49

• Static pressures are negative, in inches of water, measured per ANSI/ASHRAE Standard 70-2006

• NC based on room absorption of 10dB, re 10⁻¹² watts, measured per ANSI/ASHRAE Standard 70-2006

Heavy Duty Bar Return Grilles

specialized grilles

33 / 30 (RL / RS)

33RL

- 1/2" blade spacing
- 38° fixed deflection
- 16-gauge border, 14-gauge blades
- Support bars 6 inches on center
- Blades parallel to the long dimension

33RS

- Same as 33RL with blades parallel to the short dimension

30RL

- 3/8" blade spacing
- 0° fixed deflection
- 16-gauge border, 14-gauge blades
- Support bars 6 inches on center
- Blades parallel to the long dimension

30RS

- Same as 30RL with blades parallel to the short dimension

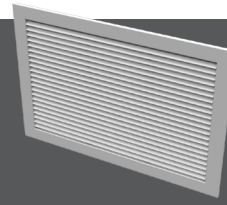

33RL

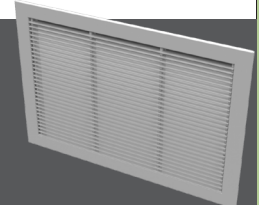

30RL



metric sizes



gymnasiums



rugged areas



See website for Specifications

AVAILABLE MODELS:

38° Deflection Models

33RL
33RS

0° Deflection Models

30RL
30RS

FINISH

Standard Finish - #26 White

OVERVIEW

Grilles / Steel

Heavy duty return grilles in steel or aluminum construction are great for use in gymnasiums and other areas where rugged construction is required. Available in 0° or angled deflection and standard or filter grille configurations.

PRODUCTS INCLUDE

- Available Border Type:
 - #1 - Surface Mount
- Countersunk Screw Holes
- #8 x 1 1/4" Long Phillips Flat Head Sheet Metal Screws, Painted White
- Optional Steel Opposed-Blade Damper

DIMENSIONS

33 / 30 (RL / RS) DIMENSIONS

38° Deflection Models 33RL / RS - Border Type 1

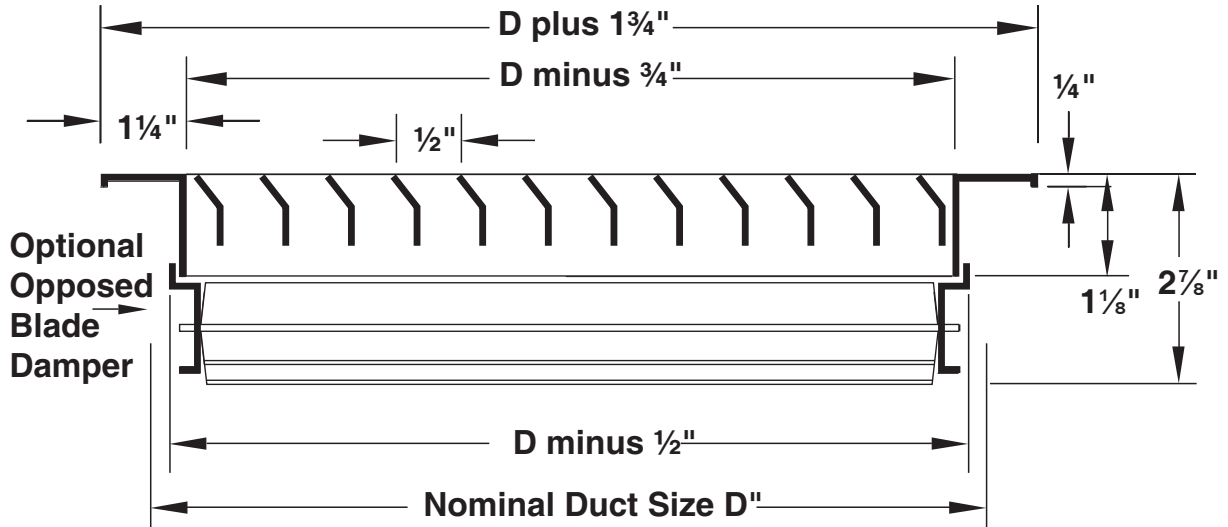

Available sizes (D" x D") Border Type 1 are 6 x 4 inches through 48 x 48 inches in 1" increments
Odd and fractional sizes are available at additional cost

0° Deflection Models 30RL / RS - Border Type 1

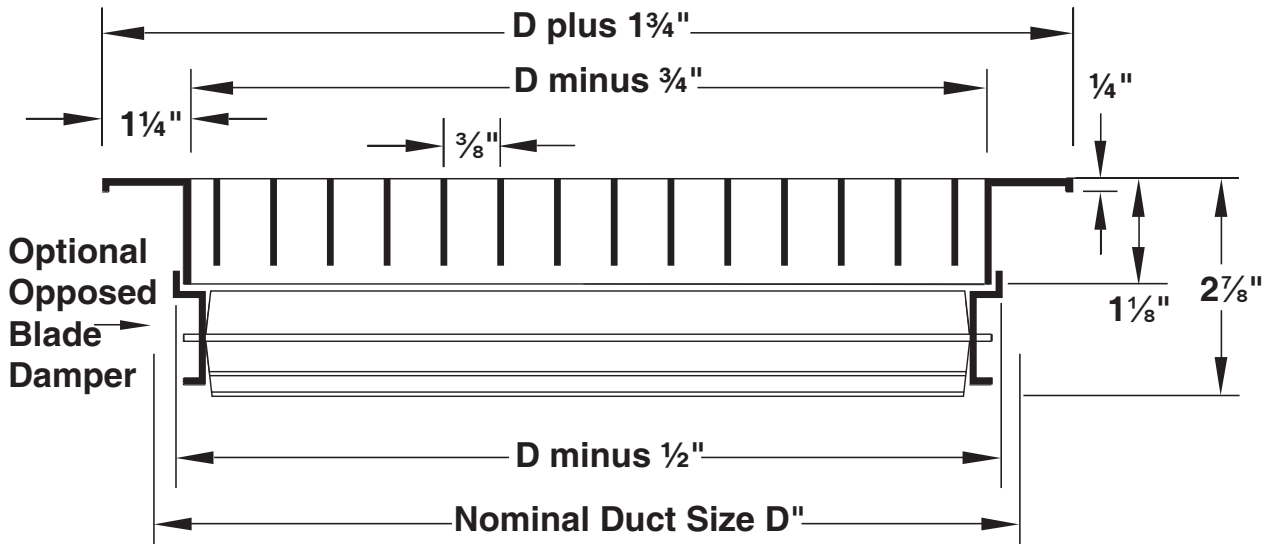

Available sizes (D" x D") Border Type 1 are 6 x 4 inches through 48 x 48 inches in 1" increments
Odd and fractional sizes are available at additional cost

33 / 30 (RFL / RFS)

33RFL

- ½" blade spacing
- 38° fixed deflection
- 16-gauge border, 14-gauge blades
- Support bars 6 inches on center
- Blades parallel to the long dimension
- 1" filter frame

33RFS

- Same as 33RFL with blades parallel to the short dimension

30RFL

- ⅜" blade spacing
- 0° fixed deflection
- 16-gauge border, 14-gauge blades
- Support bars 6 inches on center

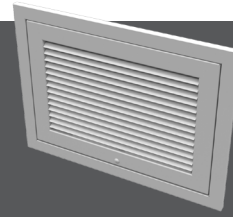

33RFL

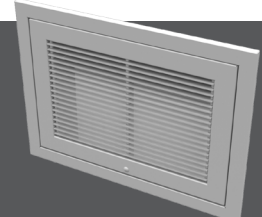

30RFL

- Blades parallel to the long dimension
- 1" filter frame

30RFS

- Same as 30RFL with blades parallel to the short dimension



metric sizes



gymnasiums



rugged areas



See website for Specifications

AVAILABLE MODELS:

38° Deflection Models

33RFL
33RFS

0° Deflection Models

30RFL
30RFS

FINISH

Standard Finish - #26 White

OVERVIEW

Grilles / Steel

Heavy duty return grilles in steel or aluminum construction are great for use in gymnasiums and other areas where rugged construction is required. Available in 0° or angled deflection and standard or filter grille configurations.

For Performance Data, refer to page I33 for base model and add pressure drop to the installed filter

PRODUCTS INCLUDE

- Available Border Type:
#1 - Surface Mount
- Hidden Screw Holes
- #8 x 1¼" Long Phillips Flat Head Sheet Metal Screws, Painted White
- Filter by Others
- Optional Steel Opposed-Blade Damper

DIMENSIONS

Redefine your comfort zone™ | www.titus-hvac.com

33 / 30 (RFL / RFS) DIMENSIONS

38° Deflection Models 33RFL / RFS - Border Type 1

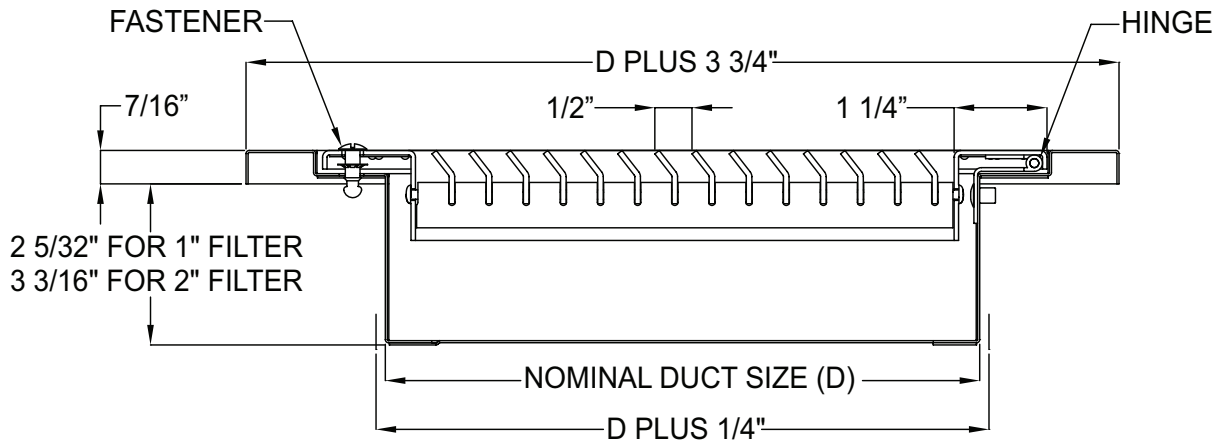

Duct opening should be nominal duct size (D) plus 1/4"
Side Cross-Sectional View:
Border Type 1 (Surface Mount)

0° Deflection Models 30RFL / RFS - Border Type 1

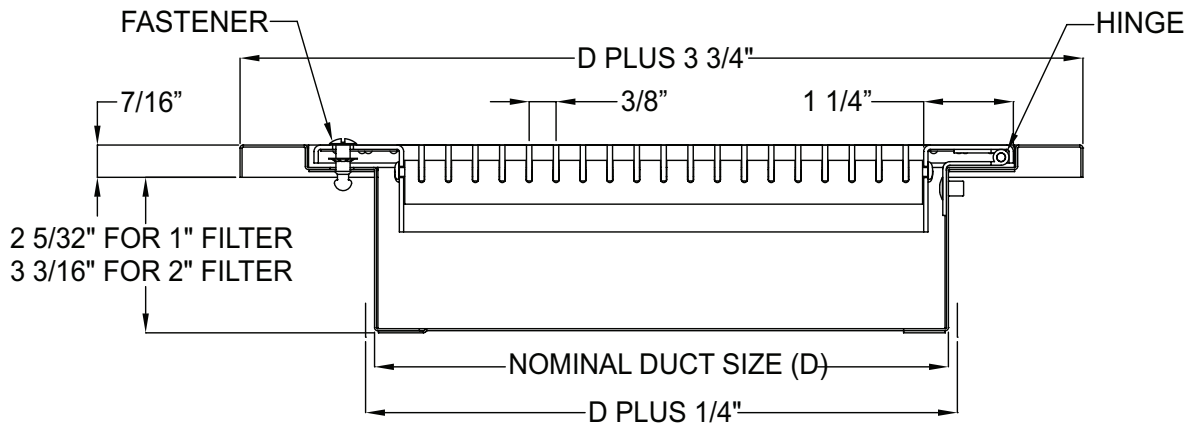

Duct opening should be nominal duct size (D) plus 1/4"
Side Cross-Sectional View:
Border Type 1 (Surface Mount)

Please refer to page I85 for Hinge Locations

DIMENSIONS

33R RETURN / 1/2" SPACING / 38° DEFLECTION
PERFORMANCE BASED ON NOMINAL SIZES SHOWN IN BOLD

Nominal Duct Size (in.)	Nominal Duct Area sq. ft	Core Area sq. ft	Core Velocity Velocity Pressure Neg. Static Pressure	NC 10		NC 20		NC 30			NC 40	
				200 0.002 0.010	300 0.006 0.023	400 0.010 0.040	500 0.016 0.063	600 0.022 0.090	700 0.031 0.123	800 0.040 0.161	900 0.050 0.203	1000 0.062 0.251
6x6	0.25	0.19	Airflow, cfm NC	38 -	57 -	76 -	95 14	114 20	133 25	152 30	171 34	190 37
8x6	0.33	0.26	Airflow, cfm NC	52 -	78 -	104 -	130 16	156 22	182 27	208 31	234 35	260 38
10x6	0.42	0.34	Airflow, cfm NC	68 -	102 -	136 -	170 17	204 23	238 28	272 32	306 36	340 40
8x8	0.44	0.37	Airflow, cfm NC	74 -	111 -	148 -	185 17	222 23	259 28	296 33	333 37	370 40
12x6	0.50	0.41	Airflow, cfm NC	82 -	123 -	164 -	205 18	246 24	287 29	328 33	369 37	410 40
14x6	0.58	0.48	Airflow, cfm NC	96 -	144 -	192 11	240 18	288 24	336 29	384 34	432 38	480 41
16x6	0.67	0.57	Airflow, cfm	114	171	228	285	342	399	456	513	570
12x8			NC	-	-	12	19	25	30	35	38	42
10x10	0.69	0.59	Airflow, cfm NC	118 -	177 -	236 12	295 19	354 25	413 30	472 35	531 39	590 42
18x6	0.75	0.63	Airflow, cfm NC	126 -	189 -	252 12	315 20	378 26	441 31	504 35	567 39	630 42
20x6	0.83	0.72	Airflow, cfm	144	216	288	360	432	504	576	648	720
12x10			NC	-	-	13	20	26	31	36	39	43
22x6	0.92	0.77	Airflow, cfm NC	154 -	231 -	308 13	385 20	462 26	539 31	616 36	693 40	770 43
24x6	1.00	0.88	Airflow, cfm	176	264	352	440	528	616	704	792	880
12x12			NC	-	-	14	21	27	32	36	40	44
30x6	1.25	1.11	Airflow, cfm	222	333	444	555	666	777	888	999	1110
18x10			NC	-	-	15	22	28	33	37	41	45
14x14	1.36	1.22	Airflow, cfm NC	244 -	366 -	488 15	610 22	732 28	854 33	976 38	1098 42	1220 45
36x6	1.50	1.35	Airflow, cfm	270	405	540	675	810	945	1080	1215	1350
18x12			NC	-	-	16	23	29	34	38	42	46
22x10	1.53	1.37	Airflow, cfm NC	274 -	411 -	548 16	685 23	822 29	959 34	1096 38	1233 42	1370 46
30x8	1.67	1.49	Airflow, cfm	298	447	596	745	894	1043	1192	1341	1490
24x10			NC	-	-	16	23	29	34	39	43	46
42x6	1.75	1.59	Airflow, cfm	318	477	636	795	954	1113	1272	1431	1590
18x14			NC	-	-	16	24	30	35	39	43	46
16x16	1.78	1.62	Airflow, cfm NC	324 -	486 -	648 16	810 24	972 30	1134 35	1296 39	1458 43	1620 46
24x12	2.00	1.82	Airflow, cfm	364	546	728	910	1092	1274	1456	1638	1820
18x16			NC	-	-	17	24	30	35	40	43	47
18x18	2.25	2.07	Airflow, cfm NC	414 -	621 -	828 18	1035 25	1242 31	1449 36	1656 40	1863 44	2070 47
24x14	2.33	2.14	Airflow, cfm NC	428 -	642 -	856 18	1070 25	1284 31	1498 36	1712 40	1926 44	2140 48
30x12	2.50	2.29	Airflow, cfm NC	458 -	687 -	916 18	1145 25	1374 31	1603 36	1832 41	2061 44	2290 48
24x16	2.67	2.46	Airflow, cfm NC	492 -	738 -	984 18	1230 26	1476 31	1722 37	1968 41	2214 45	2460 48
20x20	2.78	2.57	Airflow, cfm NC	514 -	771 -	1028 18	1285 26	1542 32	1799 37	2056 41	2313 45	2570 48
36x12	3.00	2.75	Airflow, cfm NC	550 -	825 -	1100 19	1375 26	1650 32	1925 37	2200 41	2475 45	2750 49
30x16	3.33	3.11	Airflow, cfm	622	933	1244	1555	1866	2177	2488	2799	3110
24x20			NC	-	-	19	27	33	38	42	46	49
22x22	3.36	3.14	Airflow, cfm NC	628 -	942 -	1256 19	1570 27	1884 33	2198 38	2512 42	2826 46	3140 49
42x12	3.50	3.22	Airflow, cfm	644	966	1288	1610	1932	2254	2576	2898	3220
36x14			NC	-	-	19	27	33	38	42	46	49
24x22	3.67	3.43	Airflow, cfm NC	686 -	1029 -	1372 20	1715 27	2058 33	2401 38	2744 42	3087 46	3430 50
30x18	3.75	3.50	Airflow, cfm NC	700 -	1050 -	1400 20	1750 27	2100 33	2450 38	2800 42	3150 46	3500 50

NC 50

• Static pressures are negative, in inches of water, measured per ANSI/ASHRAE Standard 70-2006

• NC based on room absorption of 10dB, re 10⁻¹² watts, measured per ANSI/ASHRAE Standard 70-2006

33R RETURN / 1/2" SPACING / 38° DEFLECTION
PERFORMANCE BASED ON NOMINAL SIZES SHOWN IN BOLD

Nominal Duct Size (in.)	Nominal Duct Area sq. ft	Core Area sq. ft	Core Velocity Velocity Pressure Neg. Static Pressure	NC 10		NC 20		NC 30		NC 40		NC 50	
				200 0.002 0.010	300 0.006 0.023	400 0.010 0.040	500 0.016 0.063	600 0.022 0.090	700 0.031 0.123	800 0.040 0.161	900 0.050 0.203	1000 0.062 0.251	
48x12 24x24	4.00	3.75	Airflow, cfm NC	750 -	1125 11	1500 20	1875 27	2250 33	2625 38	3000 43	3375 47	3750 50	
36x18	4.50	4.22	Airflow, cfm NC	844 -	1266 11	1688 21	2110 28	2532 34	2954 39	3376 43	3798 47	4220 51	
36x20 30x24	5.00	4.71	Airflow, cfm NC	942 -	1413 12	1884 21	2355 28	2826 34	3297 39	3768 44	4239 48	4710 51	
42x18	5.25	4.94	Airflow, cfm NC	988 -	1482 12	1976 21	2470 29	2964 35	3458 40	3952 44	4446 48	4940 51	
28x28	5.44	5.16	Airflow, cfm NC	1032 -	1548 12	2064 21	2580 29	3096 35	3612 40	4128 44	4644 48	5160 51	
42x20 30x28	5.83	5.51	Airflow, cfm NC	1102 -	1653 12	2204 22	2755 29	3306 35	3857 40	4408 44	4959 48	5510 52	
48x18 36x24	6.00	5.66	Airflow, cfm NC	1132 -	1698 12	2264 22	2830 29	3396 35	3962 40	4528 45	5094 48	5660 52	
30x30	6.25	5.94	Airflow, cfm NC	1188 -	1782 13	2376 22	2970 29	3564 35	4158 40	4752 45	5346 49	5940 52	
42x24 36x28	7.00	6.66	Airflow, cfm NC	1332 -	1998 13	2664 23	3330 30	3996 36	4662 41	5328 45	5994 49	6660 52	
46x22	7.03	6.68	Airflow, cfm NC	1336 -	2004 13	2672 23	3340 30	4008 36	4676 41	5344 45	6012 49	6680 53	
32x32	7.11	6.78	Airflow, cfm NC	1356 -	2034 13	2712 23	3390 30	4068 36	4746 41	5424 45	6102 49	6780 53	
36x30	7.50	7.16	Airflow, cfm NC	1432 -	2148 14	2864 23	3580 30	4296 36	5012 41	5728 46	6444 49	7160 53	
48x24 36x32	8.00	7.63	Airflow, cfm NC	1526 -	2289 14	3052 23	3815 30	4578 36	5341 41	6104 46	6867 50	7630 53	
34x34	8.03	7.68	Airflow, cfm NC	1536 -	2304 14	3072 23	3840 30	4608 36	5376 41	6144 46	6912 50	7680 53	
36x34	8.50	8.14	Airflow, cfm NC	1628 -	2442 14	3256 23	4070 31	4884 37	5698 42	6512 46	7326 50	8140 53	
42x30	8.75	8.38	Airflow, cfm NC	1676 -	2514 14	3352 24	4190 31	5028 37	5866 42	6704 46	7542 50	8380 53	
36x36	9.00	8.63	Airflow, cfm NC	1726 -	2589 14	3452 24	4315 31	5178 37	6041 42	6904 46	7767 50	8630 54	
42x34 48x30	10.00	9.60	Airflow, cfm NC	1920 -	2880 15	3840 24	4800 31	5760 37	6720 42	7680 47	8640 51	9600 54	
38x38	10.03	9.64	Airflow, cfm NC	1928 -	2892 15	3856 24	4820 31	5784 37	6748 42	7712 47	8676 51	9640 54	
42x36	10.50	10.10	Airflow, cfm NC	2020 -	3030 15	4040 24	5050 32	6060 38	7070 43	8080 47	9090 51	10100 54	
46x34	10.86	10.45	Airflow, cfm NC	2090 -	3135 15	4180 25	5225 32	6270 38	7315 43	8360 47	9405 51	10450 54	
42x38	11.08	10.67	Airflow, cfm NC	2134 -	3201 15	4268 25	5335 32	6402 38	7469 43	8536 47	9603 51	10670 55	
40x40	11.11	10.70	Airflow, cfm NC	2140 -	3210 15	4280 25	5350 32	6420 38	7490 43	8560 47	9630 51	10700 55	
48x36	12.00	11.57	Airflow, cfm NC	2314 -	3471 16	4628 25	5785 32	6942 38	8099 43	9256 48	10413 51	11570 55	
42x42	12.25	11.82	Airflow, cfm NC	2364 -	3546 16	4728 25	5910 32	7092 38	8274 43	9456 48	10638 52	11820 55	
44x44	13.44	12.99	Airflow, cfm NC	2598 -	3897 16	5196 25	6495 33	7794 39	9093 44	10392 48	11691 52	12990 55	
48x42	14.00	13.54	Airflow, cfm NC	2708 -	4062 16	5416 26	6770 33	8124 39	9478 44	10832 48	12186 52	13540 56	
46x46	14.69	14.22	Airflow, cfm NC	2844 -	4266 16	5688 26	7110 33	8532 39	9954 44	11376 49	12798 52	14220 56	
48x46	15.33	14.85	Airflow, cfm NC	2970 -	4455 17	5940 26	7425 33	8910 39	10395 44	11880 49	13365 53	14850 56	
48x48	16.00	15.50	Airflow, cfm NC	3100 -	4650 17	6200 26	7750 34	9300 39	10850 45	12400 49	13950 53	15500 56	

• Static pressures are negative, in inches of water, measured per ANSI/ASHRAE Standard 70-2006

• NC based on room absorption of 10dB, re 10⁻¹² watts, measured per ANSI/ASHRAE Standard 70-2006

30R RETURN / 3/8" SPACING / 0° DEFLECTION
PERFORMANCE BASED ON NOMINAL SIZES SHOWN IN BOLD

Nominal Duct Size (in.)	Nominal Duct Area sq. ft	Core Area sq. ft	Core Velocity Velocity Pressure Neg. Static Pressure	NC 20					NC 30			NC 40	
				200 0.002 0.006	300 0.006 0.013	400 0.010 0.022	500 0.016 0.035	600 0.022 0.050	800 0.040 0.090	1000 0.062 0.140	1200 0.090 0.202	1400 0.122 0.275	
6x6	0.25	0.19	Airflow, cfm NC	38 -	57 -	76 -	95 12	114 16	152 23	190 28	228 32	266 35	
8x6	0.33	0.26	Airflow, cfm NC	52 -	78 -	104 -	130 13	156 17	208 24	260 29	312 33	364 36	
10x6	0.42	0.34	Airflow, cfm NC	68 -	102 -	136 -	170 15	204 19	272 25	340 30	408 34	476 38	
8x8	0.44	0.37	Airflow, cfm NC	74 -	111 -	148 -	185 15	222 19	296 25	370 30	444 35	518 38	
12x6	0.50	0.41	Airflow, cfm NC	82 -	123 -	164 -	205 15	246 19	328 26	410 31	492 35	574 38	
14x6	0.58	0.48	Airflow, cfm NC	96 -	144 -	192 11	240 16	288 20	384 27	480 32	576 36	672 39	
16x6 12x8	0.67	0.57	Airflow, cfm NC	114 -	171 -	228 12	285 17	342 21	456 27	570 32	684 36	798 40	
10x10	0.69	0.59	Airflow, cfm NC	118 -	177 -	236 12	295 17	354 21	472 27	590 32	708 37	826 40	
18x6	0.75	0.63	Airflow, cfm NC	126 -	189 -	252 12	315 17	378 21	504 28	630 33	756 37	882 40	
20x6 12x10	0.83	0.72	Airflow, cfm NC	144 -	216 -	288 13	360 18	432 22	576 28	720 33	864 37	1008 41	
22x6	0.92	0.77	Airflow, cfm NC	154 -	231 -	308 13	385 18	462 22	616 29	770 34	924 38	1078 41	
24x6 12x12	1.00	0.88	Airflow, cfm NC	176 -	264 -	352 14	440 19	528 23	704 29	880 34	1056 38	1232 42	
30x6 18x10	1.25	1.11	Airflow, cfm NC	222 -	333 -	444 15	555 20	666 24	888 30	1110 35	1332 39	1554 43	
14x14	1.36	1.22	Airflow, cfm NC	244 -	366 -	488 15	610 20	732 24	976 31	1220 36	1464 40	1708 43	
36x6 18x12	1.50	1.35	Airflow, cfm NC	270 -	405 -	540 15	675 21	810 25	1080 31	1350 36	1620 40	1890 44	
22x10	1.53	1.37	Airflow, cfm NC	274 -	411 -	548 16	685 21	822 25	1096 31	1370 36	1644 40	1918 44	
30x8 24x10	1.67	1.49	Airflow, cfm NC	298 -	447 -	596 16	745 21	894 25	1192 31	1490 36	1788 41	2086 44	
42x6 18x14	1.75	1.59	Airflow, cfm NC	318 -	477 -	636 16	795 21	954 25	1272 32	1590 37	1908 41	2226 44	
16x16	1.78	1.62	Airflow, cfm NC	324 -	486 -	648 16	810 21	972 25	1296 32	1620 37	1944 41	2268 44	
24x12 18x16	2.00	1.82	Airflow, cfm NC	364 -	546 -	728 17	910 22	1092 26	1456 32	1820 37	2184 41	2548 45	
18x18	2.25	2.07	Airflow, cfm NC	414 -	621 11	828 17	1035 22	1242 26	1656 33	2070 38	2484 42	2898 45	
24x14	2.33	2.14	Airflow, cfm NC	428 -	642 11	856 18	1070 23	1284 27	1712 33	2140 38	2568 42	2996 46	
30x12	2.50	2.29	Airflow, cfm NC	458 -	687 11	916 18	1145 23	1374 27	1832 33	2290 38	2748 42	3206 46	
24x16	2.67	2.46	Airflow, cfm NC	492 -	738 12	984 18	1230 23	1476 27	1968 34	2460 39	2952 43	3444 46	
20x20	2.78	2.57	Airflow, cfm NC	514 -	771 12	1028 18	1285 23	1542 27	2056 34	2570 39	3084 43	3598 46	
36x12	3.00	2.75	Airflow, cfm NC	550 -	825 12	1100 19	1375 24	1650 28	2200 34	2750 39	3300 43	3850 47	
30x16 24x20	3.33	3.11	Airflow, cfm NC	622 -	933 13	1244 19	1555 24	1866 28	2488 35	3110 40	3732 44	4354 47	
22x22	3.36	3.14	Airflow, cfm NC	628 -	942 13	1256 19	1570 24	1884 28	2512 35	3140 40	3768 44	4396 47	
42x12 36x14	3.50	3.22	Airflow, cfm NC	644 -	966 13	1288 19	1610 24	1932 28	2576 35	3220 40	3864 44	4508 47	
24x22	3.67	3.43	Airflow, cfm NC	686 -	1029 13	1372 20	1715 25	2058 29	2744 35	3430 40	4116 44	4802 48	
30x18	3.75	3.50	Airflow, cfm NC	700 -	1050 13	1400 20	1750 25	2100 29	2800 35	3500 40	4200 44	4900 48	

• Static pressures are negative, in inches of water, measured per ANSI/ASHRAE Standard 70-2006

• NC based on room absorption of 10dB, re 10⁻¹² watts, measured per ANSI/ASHRAE Standard 70-2006

30R RETURN / 3/8" SPACING / 0° DEFLECTION
PERFORMANCE BASED ON NOMINAL SIZES SHOWN IN BOLD

Nominal Duct Size (in.)	Nominal Duct Area sq. ft	Core Area sq. ft	Core Velocity Velocity Pressure Neg. Static Pressure	NC 20				NC 30			NC 40		NC 50	
				200 0.002 0.006	300 0.006 0.013	400 0.010 0.022	500 0.016 0.035	600 0.022 0.050	800 0.040 0.090	1000 0.062 0.140	1200 0.090 0.202	1400 0.122 0.275		
48x12 24x24	4.00	3.75	Airflow, cfm NC	750 -	1125 13	1500 20	1875 25	2250 29	3000 35	3750 40	4500 45	5250 48		
36x18	4.50	4.22	Airflow, cfm NC	844 -	1266 14	1688 20	2110 25	2532 30	3376 36	4220 41	5064 45	5908 49		
36x20 30x24	5.00	4.71	Airflow, cfm NC	942 -	1413 14	1884 21	2355 26	2826 30	3768 36	4710 41	5652 46	6594 49		
42x18	5.25	4.94	Airflow, cfm NC	988 -	1482 15	1976 21	2470 26	2964 30	3952 37	4940 42	5928 46	6916 49		
28x28 42x20 30x28	5.44	5.16	Airflow, cfm NC	1032 -	1548 15	2064 21	2580 26	3096 30	4128 37	5160 42	6192 46	7224 49		
42x20 30x28	5.83	5.51	Airflow, cfm NC	1102 -	1653 15	2204 22	2755 27	3306 31	4408 37	5510 42	6612 46	7714 50		
48x18 36x24	6.00	5.66	Airflow, cfm NC	1132 -	1698 15	2264 22	2830 27	3396 31	4528 37	5660 42	6792 46	7924 50		
30x30 42x24 36x28	6.25	5.94	Airflow, cfm NC	1188 -	1782 15	2376 22	2970 27	3564 31	4752 37	5940 42	7128 47	8316 50		
42x24 36x28	7.00	6.66	Airflow, cfm NC	1332 -	1998 16	2664 22	3330 27	3996 32	5328 38	6660 43	7992 47	9324 51		
46x22	7.03	6.68	Airflow, cfm NC	1336 -	2004 16	2672 22	3340 27	4008 32	5344 38	6680 43	8016 47	9352 51		
32x32	7.11	6.78	Airflow, cfm NC	1356 -	2034 16	2712 23	3390 28	4068 32	5424 38	6780 43	8136 47	9492 51		
36x30 48x24 36x32	7.50	7.16	Airflow, cfm NC	1432 -	2148 16	2864 23	3580 28	4296 32	5728 38	7160 43	8592 47	10024 51		
48x24 36x32	8.00	7.63	Airflow, cfm NC	1526 -	2289 17	3052 23	3815 28	4578 32	6104 39	7630 44	9156 48	10682 51		
34x34	8.03	7.68	Airflow, cfm NC	1536 -	2304 17	3072 23	3840 28	4608 32	6144 39	7680 44	9216 48	10752 51		
36x34	8.50	8.14	Airflow, cfm NC	1628 -	2442 17	3256 23	4070 28	4884 32	6512 39	8140 44	9768 48	11396 51		
42x30	8.75	8.38	Airflow, cfm NC	1676 -	2514 17	3352 23	4190 28	5028 33	6704 39	8380 44	10056 48	11732 52		
36x36 42x34 48x30	9.00	8.63	Airflow, cfm NC	1726 -	2589 17	3452 24	4315 29	5178 33	6904 39	8630 44	10356 48	12082 52		
42x34 48x30	10.00	9.60	Airflow, cfm NC	1920 -	2880 18	3840 24	4800 29	5760 33	7680 40	9600 45	11520 49	13440 52		
38x38	10.03	9.64	Airflow, cfm NC	1928 -	2892 18	3856 24	4820 29	5784 33	7712 40	9640 45	11568 49	13496 52		
42x36	10.50	10.10	Airflow, cfm NC	2020 -	3030 18	4040 24	5050 29	6060 33	8080 40	10100 45	12120 49	14140 52		
46x34	10.86	10.45	Airflow, cfm NC	2090 -	3135 18	4180 24	5225 29	6270 33	8360 40	10450 45	12540 49	14630 52		
42x38	11.08	10.67	Airflow, cfm NC	2134 -	3201 18	4268 24	5335 29	6402 34	8536 40	10670 45	12804 49	14938 53		
40x40	11.11	10.70	Airflow, cfm NC	2140 -	3210 18	4280 24	5350 29	6420 34	8560 40	10700 45	12840 49	14980 53		
48x36	12.00	11.57	Airflow, cfm NC	2314 -	3471 18	4628 25	5785 30	6942 34	9256 40	11570 45	13884 49	16198 53		
42x42	12.25	11.82	Airflow, cfm NC	2364 -	3546 18	4728 25	5910 30	7092 34	9456 40	11820 45	14184 49	16548 53		
44x44	13.44	12.99	Airflow, cfm NC	2598 -	3897 19	5196 25	6495 30	7794 34	10392 41	12990 46	15588 50	18186 53		
48x42	14.00	13.54	Airflow, cfm NC	2708 -	4062 19	5416 26	6770 31	8124 35	10832 41	13540 46	16248 50	18956 54		
46x46	14.69	14.22	Airflow, cfm NC	2844 -	4266 19	5688 26	7110 31	8532 35	11376 41	14220 46	17064 50	19908 54		
48x46	15.33	14.85	Airflow, cfm NC	2970 -	4455 19	5940 26	7425 31	8910 35	11880 41	14850 46	17820 51	20790 54		
48x48	16.00	15.50	Airflow, cfm NC	3100 11	4650 20	6200 26	7750 31	9300 35	12400 42	15500 47	18600 51	21700 54		

• Static pressures are negative, in inches of water, measured per ANSI/ASHRAE Standard 70-2006

• NC based on room absorption of 10dB, re 10⁻¹² watts, measured per ANSI/ASHRAE Standard 70-2006

63 / 60 (FL / FS)

63FL

- ½" blade spacing
- 30° fixed deflection
- Great for areas with high humidity
- Heavy duty design stands up to abuse
- Blades parallel to the long dimension
- Frame = .05" Thick / Blade = .125 Thick

63FS

- Same as 63FL with blades parallel to the short dimension

60FL

- ½" blade spacing
- 0° fixed deflection
- Great for areas with high humidity
- Heavy duty design stands up to abuse
- Blades parallel to the long dimension



63FL

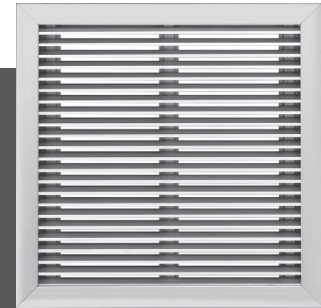

60FL

60FS

- Same as 60FL with blades parallel to the short dimension



metric sizes



humid areas



MRI compatible



rugged areas



See website for Specifications

AVAILABLE MODELS:

30° Deflection Models

63FL
63FS

0° Deflection Models

60FL
60FS

FINISH

Standard Finish - #26 White

OVERVIEW

Grilles / Aluminum

Heavy duty return grilles in steel or aluminum construction are great for use in gymnasiums and other areas where rugged construction is required. Available in 0° or angled deflection and standard or filter grille configurations.

PRODUCTS INCLUDE

- Available Border Types:
#1 - Surface Mount
- Countersunk Screw Holes
- #8 x 1¼" long Phillips Flat Head Sheet Metal Screws, Painted White
- Optional Aluminum Opposed-Blade Damper
- MRI Compatible

63 / 60 (FL / FS) DIMENSIONS

30° Deflection Model 63FL

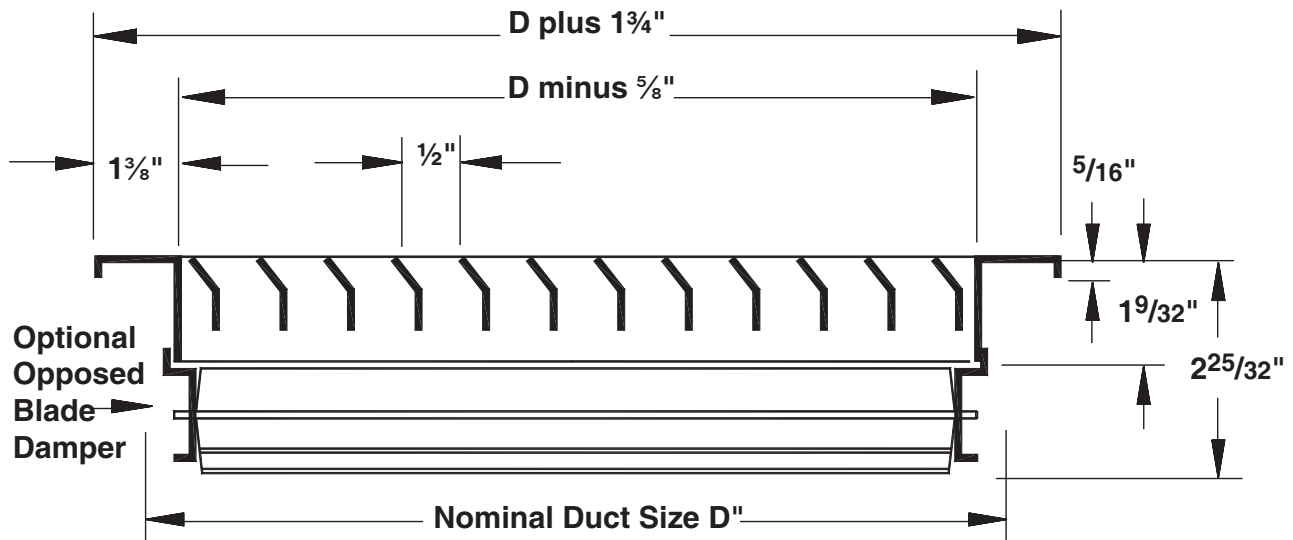

Available sizes (D" x D") Border Type 1 are 6 x 4 inches through 48 x 48 inches in 1" increments
Odd and fractional sizes are available at additional cost

0° Deflection Model 60FL

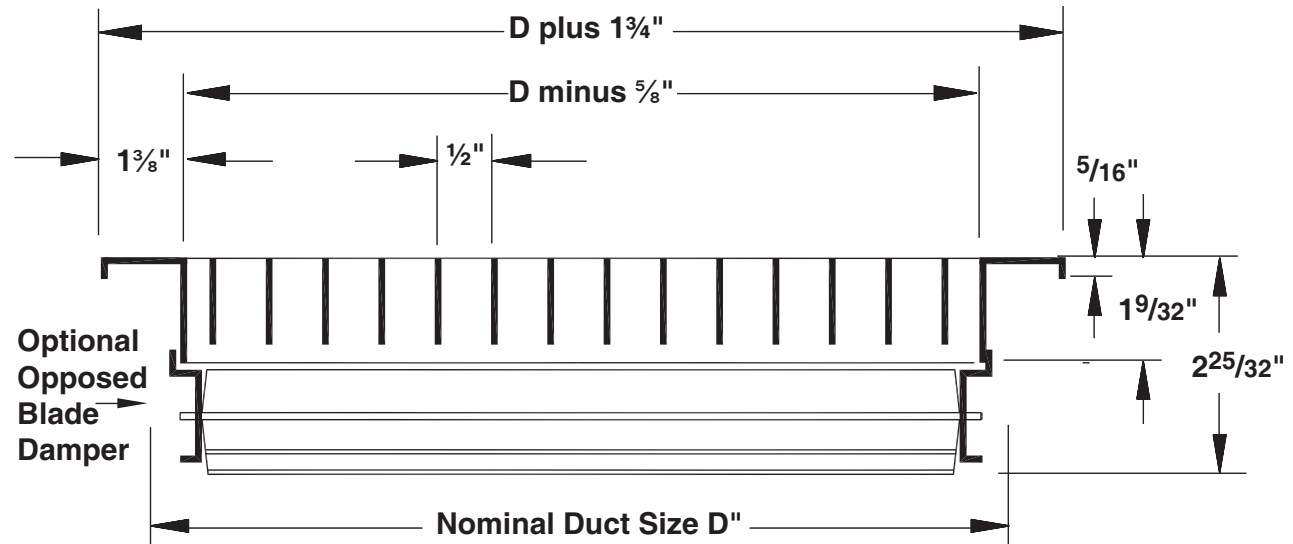

Available sizes (D" x D") Border Type 1 are 6 x 4 inches through 48 x 48 inches in 1" increments
Odd and fractional sizes are available at additional cost

PERFORMANCE DATA

specialized grilles

63F RETURN / 1/2" SPACING / 30° DEFLECTION
PERFORMANCE BASED ON NOMINAL SIZES SHOWN IN BOLD

Nominal Duct Size (IN)	Nominal Duct Area sq. ft	Core Area sq. ft	Core Velocity, FPM Velocity Pressure, IN WG Negative Static Pressure, IN WG	200	300	400	500	600	700	800	900	1000	1100	1200	1300	1400	1500
				0.002 0.009	0.006 0.020	0.010 0.035	0.016 0.055	0.022 0.079	0.031 0.108	0.040 0.140	0.050 0.178	0.062 0.219	0.075 0.265	0.090 0.316	0.105 0.371	0.122 0.430	0.140 0.494
6x6	0.25	0.12	Airflow, cfm NC	24 -	36 -	49 -	61 -	73 13	85 18	97 22	109 26	122 29	134 32	146 35	158 37	170 40	182 42
8x6	0.33	0.17	Airflow, cfm NC	34 -	51 -	68 -	85 -	102 14	119 19	136 24	153 27	170 31	187 34	204 37	221 39	238 42	255 44
10x6	0.42	0.22	Airflow, cfm NC	44 -	66 -	88 -	109 10	131 16	153 21	175 25	197 29	219 32	241 35	263 38	284 41	306 43	328 45
8x8	0.44	0.27	Airflow, cfm NC	53 -	80 -	107 -	134 11	160 17	187 22	214 26	241 30	267 33	294 36	321 39	348 42	374 44	401 46
12x6	0.50	0.27	Airflow, cfm NC	53 -	80 -	107 -	134 11	160 17	187 22	214 26	241 30	267 33	294 36	321 39	348 42	374 44	401 46
14x6	0.58	0.32	Airflow, cfm NC	63 -	95 -	126 -	158 12	190 18	221 23	253 27	284 31	316 34	348 37	379 40	411 42	442 45	474 47
18x6	0.75	0.41	Airflow, cfm NC	83 -	124 -	165 -	207 13	248 19	289 24	331 28	372 32	413 35	455 38	496 41	537 44	578 46	620 48
12x8	0.67	0.42	Airflow, cfm NC	84 -	126 -	168 -	210 13	252 19	294 24	336 28	378 32	420 35	462 39	504 41	546 44	588 46	630 49
10x10	0.69	0.47	Airflow, cfm NC	94 -	141 -	188 -	234 14	281 20	328 25	375 29	422 33	469 36	516 39	563 42	609 44	656 47	703 49
22x6	0.92	0.51	Airflow, cfm NC	102 -	153 -	204 -	255 14	306 20	357 25	408 29	459 33	510 36	561 40	613 42	664 45	715 47	766 50
12x10	0.83	0.57	Airflow, cfm NC	115 -	172 -	229 -	286 15	344 21	401 26	458 30	516 34	573 37	630 40	688 43	745 46	802 48	859 50
12x12	1.00	0.73	Airflow, cfm NC	145 -	218 -	290 -	363 16	435 22	508 27	581 31	653 35	726 38	798 41	871 44	943 47	1016 49	1089 51
18x10	1.25	0.89	Airflow, cfm NC	177 -	266 -	354 10	443 17	531 23	620 28	708 32	797 36	885 39	974 42	1063 45	1151 48	1240 50	1328 52
14x14	1.36	1.04	Airflow, cfm NC	208 -	311 -	415 11	519 18	623 24	727 29	831 33	934 37	1038 40	1142 43	1246 46	1350 49	1453 51	1557 53
22x10	1.53	1.09	Airflow, cfm NC	219 -	328 -	438 11	547 18	656 24	766 29	875 33	984 37	1094 40	1203 44	1313 46	1422 49	1531 51	1641 53
18x12	1.50	1.12	Airflow, cfm NC	224 -	336 -	449 11	561 18	673 24	785 29	897 33	1009 37	1122 41	1234 44	1346 46	1458 49	1570 51	1682 54
24x10	1.67	1.20	Airflow, cfm NC	240 -	359 -	479 11	599 19	719 25	839 29	958 34	1078 38	1198 41	1318 44	1438 47	1557 49	1677 52	1797 54
18x14	1.75	1.36	Airflow, cfm NC	272 -	407 -	543 12	679 19	815 25	950 30	1086 34	1222 38	1358 42	1493 45	1629 47	1765 50	1901 52	2036 55
16x16	1.78	1.50	Airflow, cfm NC	300 -	450 -	600 13	750 20	900 26	1050 31	1200 35	1350 39	1500 42	1650 45	1800 48	1950 51	2100 53	2250 55
24x12	2.00	1.52	Airflow, cfm NC	303 -	455 -	607 13	759 20	910 26	1062 31	1214 35	1366 39	1517 42	1669 45	1821 48	1973 51	2124 53	2276 55
18x18	2.25	1.83	Airflow, cfm NC	366 -	549 -	732 14	915 21	1098 27	1281 32	1464 36	1647 40	1830 43	2013 46	2196 49	2379 52	2562 54	2745 56
24x14	2.33	1.84	Airflow, cfm NC	367 -	551 -	735 14	918 21	1102 27	1286 32	1469 36	1653 40	1837 43	2020 46	2204 49	2388 52	2572 54	2755 56
30x12	2.50	1.91	Airflow, cfm NC	383 -	574 -	765 14	957 21	1148 27	1339 32	1531 36	1722 40	1913 43	2105 46	2296 49	2487 52	2678 54	2870 56
24x16	2.67	2.16	Airflow, cfm NC	431 -	647 -	863 15	1078 22	1294 28	1509 33	1725 37	1941 41	2156 44	2372 47	2588 50	2803 52	3019 55	3234 57
20x20	2.78	2.31	Airflow, cfm NC	462 -	693 -	924 15	1155 22	1385 28	1616 33	1847 37	2078 41	2309 44	2540 47	2771 50	3002 53	3233 55	3464 57
36x12	3.00	2.31	Airflow, cfm NC	462 -	693 -	924 15	1155 22	1385 28	1616 33	1847 37	2078 41	2309 44	2540 47	2771 50	3002 53	3233 55	3464 57
42x12	3.50	2.70	Airflow, cfm NC	541 -	811 -	1082 16	1352 23	1623 29	1893 34	2164 38	2434 42	2705 45	2975 48	3246 51	3516 54	3787 56	4057 58
24x20	3.33	2.80	Airflow, cfm NC	559 -	839 -	1118 16	1398 23	1677 29	1957 34	2236 38	2516 42	2795 45	3075 48	3354 51	3634 54	3913 56	4193 58
22x22	3.36	2.84	Airflow, cfm NC	569 -	853 -	1138 16	1422 23	1706 29	1991 34	2275 38	2559 42	2844 45	3128 49	3413 51	3697 54	3981 56	4266 58
24x22	3.67	3.11	Airflow, cfm NC	623 -	934 -	1246 16	1557 24	1869 30	2180 34	2492 39	2803 43	3115 46	3426 49	3738 52	4049 54	4360 57	4672 59

• Static pressures are negative, in inches of water, measured per ANSI/ASHRAE Standard 70-2006

• NC based on room absorption of 10dB, re 10⁻¹² watts, measured per ANSI/ASHRAE Standard 70-2006

63F RETURN / 1/2" SPACING / 30° DEFLECTION (CONTINUED)
PERFORMANCE BASED ON NOMINAL SIZES SHOWN IN BOLD

Nominal Duct Size (IN)	Nominal Duct Area sq. ft	Core Area sq. ft	Core Velocity, FPM Velocity Pressure, IN WG Negative Static Pressure, IN WG	200 0.002 0.009	250 0.004 0.014	300 0.006 0.020	350 0.008 0.027	400 0.010 0.035	450 0.013 0.044	500 0.016 0.055	550 0.019 0.066	600 0.022 0.079	650 0.026 0.093	700 0.031 0.108	750 0.035 0.123	800 0.040 0.140	850 0.045 0.159
30x18	3.75	3.12	Airflow, cfm NC	624 -	780 -	936 -	1093 12	1249 16	1405 20	1561 24	1717 27	1873 30	2029 32	2185 34	2341 37	2497 39	2653 41
24x24	4.00	3.43	Airflow, cfm NC	687 -	859 -	1030 -	1202 13	1374 17	1545 21	1717 24	1889 27	2060 30	2232 33	2404 35	2576 37	2747 39	2919 41
36x18	4.50	3.77	Airflow, cfm NC	753 -	942 -	1130 -	1319 13	1507 17	1695 21	1884 25	2072 28	2260 30	2449 33	2637 35	2826 38	3014 40	3202 42
36x20	5.00	4.25	Airflow, cfm NC	851 -	1063 -	1276 -	1489 14	1701 18	1914 22	2127 25	2339 28	2552 31	2765 34	2977 36	3190 38	3403 40	3615 42
42x18	5.25	4.41	Airflow, cfm NC	883 -	1103 -	1324 -	1545 14	1765 18	1986 22	2207 25	2427 29	2648 31	2869 34	3089 36	3310 38	3531 41	3751 43
28x28	5.44	4.78	Airflow, cfm NC	956 -	1195 -	1434 -	1673 14	1913 19	2152 22	2391 26	2630 29	2869 32	3108 34	3347 37	3586 39	3825 41	4064 43
42x20	5.83	4.98	Airflow, cfm NC	997 -	1246 -	1495 10	1744 15	1993 19	2242 23	2491 26	2740 29	2990 32	3239 35	3488 37	3737 39	3986 41	4235 43
48x18	6.00	5.06	Airflow, cfm NC	1012 -	1265 -	1518 10	1771 15	2024 19	2277 23	2530 26	2782 29	3035 32	3288 35	3541 37	3794 39	4047 41	4300 43
30x30	6.25	5.54	Airflow, cfm NC	1108 -	1385 -	1661 10	1938 15	2215 19	2492 23	2769 27	3046 30	3323 33	3600 35	3877 37	4154 40	4431 42	4707 44
46x22	7.03	6.09	Airflow, cfm NC	1219 -	1523 -	1828 11	2133 16	2438 20	2742 24	3047 27	3352 30	3656 33	3961 36	4266 38	4570 40	4875 42	5180 44
42x24	7.00	6.12	Airflow, cfm NC	1224 -	1530 -	1836 11	2143 16	2449 20	2755 24	3061 27	3367 30	3673 33	3979 36	4285 38	4591 40	4897 42	5203 44
32x32	7.11	6.35	Airflow, cfm NC	1270 -	1588 -	1905 11	2223 16	2540 20	2858 24	3175 27	3493 30	3810 33	4128 36	4445 38	4763 40	5081 42	5398 44
36x30	7.50	6.68	Airflow, cfm NC	1337 -	1671 -	2005 11	2339 16	2674 20	3008 24	3342 28	3676 31	4010 33	4345 36	4679 38	5013 41	5347 43	5681 45
48x24	8.00	7.02	Airflow, cfm NC	1403 -	1754 -	2105 11	2456 16	2807 21	3158 24	3509 28	3860 31	4210 34	4561 36	4912 39	5263 41	5614 43	5965 45
36x34	8.50	7.66	Airflow, cfm NC	1531 -	1914 -	2297 12	2680 17	3063 21	3445 25	3828 28	4211 31	4594 34	4977 37	5359 39	5742 41	6125 43	6508 45
42x30	8.75	7.83	Airflow, cfm NC	1566 -	1957 -	2349 12	2740 17	3132 21	3523 25	3915 28	4306 32	4698 34	5089 37	5481 39	5872 41	6264 44	6655 46
36x36	9.00	8.14	Airflow, cfm NC	1628 -	2036 -	2443 12	2850 17	3257 21	3664 25	4071 29	4478 32	4885 35	5293 37	5700 39	6107 42	6514 44	6921 46
48x30	10.00	8.98	Airflow, cfm NC	1795 -	2244 -	2693 13	3141 18	3590 22	4039 26	4488 29	4937 32	5385 35	5834 38	6283 40	6732 42	7181 44	7629 46
38x38	10.03	9.12	Airflow, cfm NC	1824 -	2280 -	2736 13	3193 18	3649 22	4105 26	4561 29	5017 32	5473 35	5929 38	6385 40	6841 42	7297 44	7753 46
42x36	10.50	9.54	Airflow, cfm NC	1908 -	2385 -	2861 13	3338 18	3815 22	4292 26	4769 29	5246 33	5723 35	6200 38	6677 40	7154 43	7631 45	8107 47
46x34	10.86	9.84	Airflow, cfm NC	1969 -	2461 -	2953 13	3445 18	3938 22	4430 26	4922 30	5414 33	5906 36	6398 38	6891 40	7383 43	7875 45	8367 47
42x38	11.08	10.11	Airflow, cfm NC	2022 -	2527 -	3032 13	3538 18	4043 23	4548 26	5054 30	5559 33	6065 36	6570 38	7075 41	7581 43	8086 45	8591 47
40x40	11.11	10.16	Airflow, cfm NC	2031 -	2539 -	3047 13	3555 18	4063 23	4570 26	5078 30	5586 33	6094 36	6602 38	7109 41	7617 43	8125 45	8633 47
48x36	12.00	10.93	Airflow, cfm NC	2187 -	2734 -	3280 14	3827 19	4374 23	4920 27	5467 30	6014 33	6560 36	7107 39	7654 41	8201 43	8747 45	9294 47
42x42	12.25	11.25	Airflow, cfm NC	2249 -	2812 -	3374 14	3936 19	4499 23	5061 27	5623 30	6186 33	6748 36	7310 39	7873 41	8435 43	8997 45	9560 47
44x44	13.44	12.39	Airflow, cfm NC	2478 -	3098 -	3718 14	4337 19	4957 24	5577 27	6196 31	6816 34	7435 37	8055 39	8675 42	9294 44	9914 46	10534 48
48x42	14.00	12.89	Airflow, cfm NC	2578 -	3223 -	3868 15	4512 20	5157 24	5802 28	6446 31	7091 34	7735 37	8380 39	9025 42	9669 44	10314 46	10959 48
46x46	14.69	13.59	Airflow, cfm NC	2719 -	3398 -	4078 15	4758 20	5438 24	6117 28	6797 31	7477 34	8156 37	8836 40	9516 42	10195 44	10875 46	11555 48
48x46	15.33	14.20	Airflow, cfm NC	2840 -	3549 -	4259 15	4969 20	5679 24	6389 28	7099 32	7809 35	8519 37	9229 40	9939 42	10648 45	11358 47	12068 49
48x48	16.00	14.85	Airflow, cfm NC	2970 -	3713 10	4455 15	5198 20	5940 25	6683 28	7425 32	8168 35	8910 38	9653 40	10395 43	11138 45	11881 47	12623 49

• Static pressures are negative, in inches of water, measured per ANSI/ASHRAE Standard 70-2006

• NC based on room absorption of 10dB, re 10⁻¹² watts, measured per ANSI/ASHRAE Standard 70-2006

60F RETURN / 1/2" SPACING / 0° DEFLECTION
PERFORMANCE BASED ON NOMINAL SIZES SHOWN IN BOLD

Nominal Duct Size (IN)	Nominal Duct Area sq. ft	Core Area sq. ft	Core Velocity, FPM Velocity Pressure, IN WG Negative Static Pressure, IN WG	200 0.002 0.005	300 0.006 0.012	400 0.010 0.020	500 0.016 0.032	600 0.022 0.046	700 0.031 0.063	800 0.040 0.082	900 0.050 0.104	1000 0.062 0.128	1100 0.075 0.155	1200 0.090 0.184	1300 0.105 0.216	1400 0.122 0.251	1500 0.140 0.288
6x6	0.25	0.12	Airflow, cfm NC	24 -	36 -	49 -	61 -	73 12	85 16	97 20	109 24	122 27	134 29	146 32	158 34	170 36	182 38
8x6	0.33	0.17	Airflow, cfm NC	34 -	51 -	68 -	85 -	102 13	119 17	136 21	153 25	170 28	187 30	204 33	221 35	238 37	255 39
10x6	0.42	0.22	Airflow, cfm NC	44 -	66 -	88 -	109 -	131 14	153 18	175 22	197 25	219 28	241 31	263 34	284 36	306 38	328 40
8x8	0.44	0.27	Airflow, cfm NC	53 -	80 -	107 -	134 -	160 14	187 19	214 22	241 26	267 29	294 32	321 34	348 37	374 39	401 41
12x6	0.50	0.27	Airflow, cfm NC	53 -	80 -	107 -	134 -	160 14	187 19	214 22	241 26	267 29	294 32	321 34	348 37	374 39	401 41
14x6	0.58	0.32	Airflow, cfm NC	63 -	95 -	126 -	158 -	190 15	221 19	253 23	284 26	316 29	348 32	379 35	411 37	442 39	474 41
18x6	0.75	0.41	Airflow, cfm NC	83 -	124 -	165 -	207 10	248 15	289 20	331 24	372 27	413 30	455 33	496 36	537 38	578 40	620 42
12x8	0.67	0.42	Airflow, cfm NC	84 -	126 -	168 -	210 10	252 15	294 20	336 24	378 27	420 30	462 33	504 36	546 38	588 40	630 42
10x10	0.69	0.47	Airflow, cfm NC	94 -	141 -	188 -	234 11	281 16	328 20	375 24	422 28	469 31	516 33	563 36	609 38	656 40	703 42
22x6	0.92	0.51	Airflow, cfm NC	102 -	153 -	204 -	255 11	306 16	357 21	408 24	459 28	510 31	561 34	613 36	664 39	715 41	766 43
12x10	0.83	0.57	Airflow, cfm NC	115 -	172 -	229 -	286 11	344 16	401 21	458 25	516 28	573 31	630 34	688 37	745 39	802 41	859 43
12x12	1.00	0.73	Airflow, cfm NC	145 -	218 -	290 -	363 12	435 17	508 22	581 26	653 29	726 32	798 35	871 37	943 40	1016 42	1089 44
18x10	1.25	0.89	Airflow, cfm NC	177 -	266 -	354 -	443 12	531 18	620 22	708 26	797 30	885 33	974 35	1063 38	1151 40	1240 42	1328 44
14x14	1.36	1.04	Airflow, cfm NC	208 -	311 -	415 -	519 13	623 18	727 23	831 27	934 30	1038 33	1142 36	1246 38	1350 41	1453 43	1557 45
22x10	1.53	1.09	Airflow, cfm NC	219 -	328 -	438 -	547 13	656 18	766 23	875 27	984 30	1094 33	1203 36	1313 39	1422 41	1531 43	1641 45
18x12	1.50	1.12	Airflow, cfm NC	224 -	336 -	449 -	561 13	673 18	785 23	897 27	1009 30	1122 33	1234 36	1346 39	1458 41	1570 43	1682 45
24x10	1.67	1.20	Airflow, cfm NC	240 -	359 -	479 -	599 13	719 19	839 23	958 27	1078 30	1198 34	1318 36	1438 39	1557 41	1677 43	1797 45
18x14	1.75	1.36	Airflow, cfm NC	272 -	407 -	543 -	679 14	815 19	950 24	1086 27	1222 31	1358 34	1493 37	1629 39	1765 42	1901 44	2036 46
16x16	1.78	1.50	Airflow, cfm NC	300 -	450 -	600 -	750 14	900 19	1050 24	1200 28	1350 31	1500 34	1650 37	1800 40	1950 42	2100 44	2250 46
24x12	2.00	1.52	Airflow, cfm NC	303 -	455 -	607 -	759 14	910 19	1062 24	1214 28	1366 31	1517 34	1669 37	1821 40	1973 42	2124 44	2276 46
18x18	2.25	1.83	Airflow, cfm NC	366 -	549 -	732 -	915 15	1098 20	1281 24	1464 28	1647 32	1830 35	2013 38	2196 40	2379 42	2562 44	2745 46
24x14	2.33	1.84	Airflow, cfm NC	367 -	551 -	735 -	918 15	1102 20	1286 24	1469 28	1653 32	1837 35	2020 38	2204 40	2388 42	2572 44	2755 46
30x12	2.50	1.91	Airflow, cfm NC	383 -	574 -	765 -	957 15	1148 20	1339 25	1531 28	1722 32	1913 35	2105 38	2296 40	2487 43	2678 45	2870 47
24x16	2.67	2.16	Airflow, cfm NC	431 -	647 -	863 -	1078 15	1294 20	1509 25	1725 29	1941 32	2156 35	2372 38	2588 41	2803 43	3019 45	3234 47
20x20	2.78	2.31	Airflow, cfm NC	462 -	693 -	924 -	1155 15	1385 21	1616 25	1847 29	2078 32	2309 36	2540 38	2771 41	3002 43	3233 45	3464 47
36x12	3.00	2.31	Airflow, cfm NC	462 -	693 -	924 -	1155 15	1385 21	1616 25	1847 29	2078 32	2309 36	2540 38	2771 41	3002 43	3233 45	3464 47
42x12	3.50	2.70	Airflow, cfm NC	541 -	811 -	1082 -	1352 16	1623 21	1893 26	2164 30	2434 33	2705 36	2975 39	3246 41	3516 44	3787 46	4057 48
24x20	3.33	2.80	Airflow, cfm NC	559 -	839 -	1118 -	1398 16	1677 21	1957 26	2236 30	2516 33	2795 36	3075 39	3354 41	3634 44	3913 46	4193 48
22x22	3.36	2.84	Airflow, cfm NC	569 -	853 -	1138 10	1422 16	1706 21	1991 26	2275 30	2559 33	2844 36	3128 39	3413 41	3697 44	3981 46	4266 48
24x22	3.67	3.11	Airflow, cfm NC	623 -	934 -	1246 10	1557 16	1869 22	2180 26	2492 30	2803 33	3115 36	3426 39	3738 42	4049 44	4360 46	4672 48

• Static pressures are negative, in inches of water, measured per ANSI/ASHRAE Standard 70-2006

• NC based on room absorption of 10dB, re 10⁻¹² watts, measured per ANSI/ASHRAE Standard 70-2006

60F RETURN / 1/2" SPACING / 0° DEFLECTION (CONTINUED)
PERFORMANCE BASED ON NOMINAL SIZES SHOWN IN BOLD

Nominal Duct Size (IN)	Nominal Duct Area sq. ft	Core Area sq. ft	Core Velocity, FPM Velocity Pressure, IN WG Negative Static Pressure, IN WG	300 0.006 0.012	350 0.008 0.016	400 0.010 0.020	450 0.013 0.026	500 0.016 0.032	550 0.019 0.039	600 0.022 0.046	650 0.026 0.054	700 0.031 0.063	800 0.040 0.082	900 0.050 0.104	1000 0.062 0.128	1100 0.075 0.155	1200 0.090 0.184
30x18	3.75	3.12	Airflow, cfm NC	936 -	1093 -	1249 10	1405 13	1561 16	1717 19	1873 22	2029 24	2185 26	2497 30	2809 33	3122 36	3434 39	3746 42
24x24	4.00	3.43	Airflow, cfm NC	1030 -	1202 -	1374 10	1545 14	1717 17	1889 19	2060 22	2232 24	2404 26	2747 30	3091 34	3434 37	3777 40	4121 42
36x18	4.50	3.77	Airflow, cfm NC	1130 -	1319 -	1507 10	1695 14	1884 17	2072 20	2260 22	2449 24	2637 27	3014 31	3391 34	3767 37	4144 40	4521 42
36x20	5.00	4.25	Airflow, cfm NC	1276 -	1489 -	1701 11	1914 14	2127 17	2339 20	2552 23	2765 25	2977 27	3403 31	3828 34	4253 37	4679 40	5104 43
42x18	5.25	4.41	Airflow, cfm NC	1324 -	1545 -	1765 11	1986 14	2207 17	2427 20	2648 23	2869 25	3089 27	3531 31	3972 34	4413 38	4855 40	5296 43
28x28	5.44	4.78	Airflow, cfm NC	1434 -	1673 -	1913 11	2152 15	2391 18	2630 20	2869 23	3108 25	3347 27	3825 31	4303 35	4781 38	5259 41	5738 43
42x20	5.83	4.98	Airflow, cfm NC	1495 -	1744 -	1993 11	2242 15	2491 18	2740 20	2990 23	3239 25	3488 28	3986 31	4484 35	4983 38	5481 41	5979 43
48x18	6.00	5.06	Airflow, cfm NC	1518 -	1771 -	2024 11	2277 15	2530 18	2782 21	3035 23	3288 25	3541 28	4047 31	4553 35	5059 38	5565 41	6071 43
30x30	6.25	5.54	Airflow, cfm NC	1661 -	1938 -	2215 12	2492 15	2769 18	3046 21	3323 23	3600 26	3877 28	4431 32	4984 35	5538 38	6092 41	6646 44
46x22	7.03	6.09	Airflow, cfm NC	1828 -	2133 -	2438 12	2742 15	3047 18	3352 21	3656 24	3961 26	4266 28	4875 32	5484 35	6094 38	6703 41	7313 44
42x24	7.00	6.12	Airflow, cfm NC	1836 -	2143 -	2449 12	2755 15	3061 18	3367 21	3673 24	3979 26	4285 28	4897 32	5509 35	6122 39	6734 41	7346 44
32x32	7.11	6.35	Airflow, cfm NC	1905 -	2223 -	2540 12	2858 15	3175 18	3493 21	3810 24	4128 26	4445 28	5081 32	5716 36	6351 39	6986 41	7621 44
36x30	7.50	6.68	Airflow, cfm NC	2005 -	2339 -	2674 12	3008 16	3342 19	3676 21	4010 24	4345 26	4679 28	5347 32	6016 36	6684 39	7352 42	8021 44
48x24	8.00	7.02	Airflow, cfm NC	2105 -	2456 -	2807 12	3158 16	3509 19	3860 22	4210 24	4561 26	4912 29	5614 32	6316 36	7017 39	7719 42	8421 44
36x34	8.50	7.66	Airflow, cfm NC	2297 -	2680 -	3063 13	3445 16	3828 19	4211 22	4594 24	4977 27	5359 29	6125 33	6891 36	7656 39	8422 42	9188 44
42x30	8.75	7.83	Airflow, cfm NC	2349 -	2740 -	3132 13	3523 16	3915 19	4306 22	4698 24	5089 27	5481 29	6264 33	7047 36	7830 39	8613 42	9396 45
36x36	9.00	8.14	Airflow, cfm NC	2443 -	2850 -	3257 13	3664 16	4071 19	4478 22	4885 25	5293 27	5700 29	6514 33	7328 36	8142 39	8957 42	9771 45
48x30	10.00	8.98	Airflow, cfm NC	2693 -	3141 -	3590 13	4039 16	4488 20	4937 22	5385 25	5834 27	6283 29	7181 33	8078 37	8976 40	9873 42	10771 45
38x38	10.03	9.12	Airflow, cfm NC	2736 -	3193 -	3649 13	4105 16	4561 20	5017 22	5473 25	5929 27	6385 29	7297 33	8209 37	9122 40	10034 42	10946 45
42x36	10.50	9.54	Airflow, cfm NC	2861 -	3338 -	3815 13	4292 17	4769 20	5246 22	5723 25	6200 27	6677 29	7631 33	8584 37	9538 40	10492 43	11446 45
46x34	10.86	9.84	Airflow, cfm NC	2953 -	3445 -	3938 13	4430 17	4922 20	5414 23	5906 25	6398 27	6891 30	7875 33	8859 37	9844 40	10828 42	11813 45
42x38	11.08	10.11	Airflow, cfm NC	3032 -	3538 -	4043 13	4548 17	5054 20	5559 23	6065 25	6570 27	7075 30	8086 34	9097 37	10108 40	11118 43	12129 45
40x40	11.11	10.16	Airflow, cfm NC	3047 -	3555 -	4063 13	4570 17	5078 20	5586 23	6094 25	6602 28	7109 30	8125 34	9141 37	10156 40	11172 43	12188 45
48x36	12.00	10.93	Airflow, cfm NC	3280 -	3827 10	4374 14	4920 17	5467 20	6014 23	6560 25	7107 28	7654 30	8747 34	9841 37	10934 40	12027 43	13121 46
42x42	12.25	11.25	Airflow, cfm NC	3374 -	3936 10	4499 14	5061 17	5623 20	6186 23	6748 25	7310 28	7873 30	8997 34	10122 37	11247 40	12371 43	13496 46
44x44	13.44	12.39	Airflow, cfm NC	3718 -	4337 10	4957 14	5577 17	6196 20	6816 23	7435 26	8055 28	8675 30	9914 34	11153 38	12392 41	13632 43	14871 46
48x42	14.00	12.89	Airflow, cfm NC	3868 -	4512 10	5157 14	5802 18	6446 21	7091 23	7735 26	8380 28	9025 30	10314 34	11603 38	12892 41	14182 44	15471 46
46x46	14.69	13.59	Airflow, cfm NC	4078 -	4758 10	5438 14	6117 18	6797 21	7477 24	8156 26	8836 28	9516 31	10875 34	12234 38	13594 41	14953 44	16313 46
48x46	15.33	14.20	Airflow, cfm NC	4259 -	4969 11	5679 14	6389 18	7099 21	7809 24	8519 26	9229 29	9939 31	11358 35	12778 38	14198 41	15618 44	17038 46
48x48	16.00	14.85	Airflow, cfm NC	4455 -	5198 11	5940 15	6683 18	7425 21	8168 24	8910 26	9653 29	10395 31	11881 35	13366 38	14851 41	16336 44	17821 47

• Static pressures are negative, in inches of water, measured per ANSI/ASHRAE Standard 70-2006

• NC based on room absorption of 10dB, re 10⁻¹² watts, measured per ANSI/ASHRAE Standard 70-2006

Spiral Duct Mounted Grilles

specialized grilles

S301 / S300 (FL / FS)

S301FL (Single Deflection)

- 3/4" blade spacing
- Individually adjustable blades
- Radius endcaps match duct to avoid installation cost of duct taps
- Blades parallel to the long dimension

S301FS

- Same as S301FL with blades parallel to the short dimension

S300FL (Double Deflection)

- 3/4" blade spacing
- Individually adjustable blades
- Radius endcaps match duct to avoid installation cost of duct taps
- Blades parallel to the long dimension

S300FS

- Same as S300FL with blades parallel to the short dimension

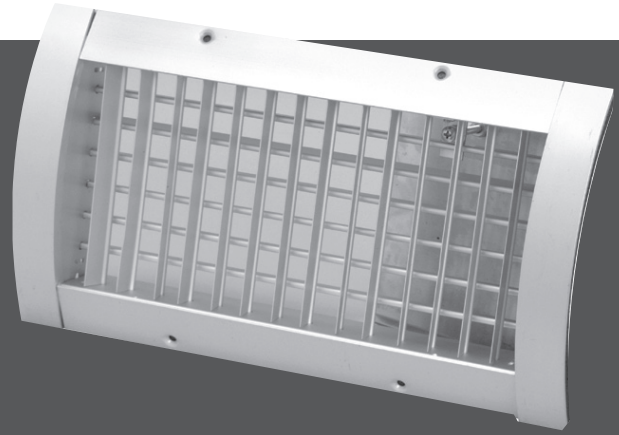

S301 / S300 (FL / FS)



duct mounted

AVAILABLE MODELS:

Single Deflection Models:

S301FL
S301FS

Double Deflection Models:

S300FL
S300FS

FINISHES

Standard Finish - #26 White or #34 Clear Anodize

OVERVIEW

Spiral Grilles mount directly to the duct, eliminating the need for duct taps. They are available in two border styles: S series for radius end cap to match duct diameter, and US (Universal) series which can be used on any duct diameter. Each grille has a gasket to provide a tight seal to the duct.

PRODUCTS INCLUDE

- Material: Aluminum extruded borders and blades
- Countersunk screw holes and curved end caps
- Foam gasketing standard for tight seal
- Optional ASD-Air scoop device



See website for Specifications

DIMENSIONS

S301 / S300 (FL / FS) DIMENSIONS

Height	Min : Max Duct Diameter
3"	6" : 36"
4"	8" : 36"
6"	10" : 36"
8"	12" : 36"
10"	14" : 36"
12"	16" : 36"

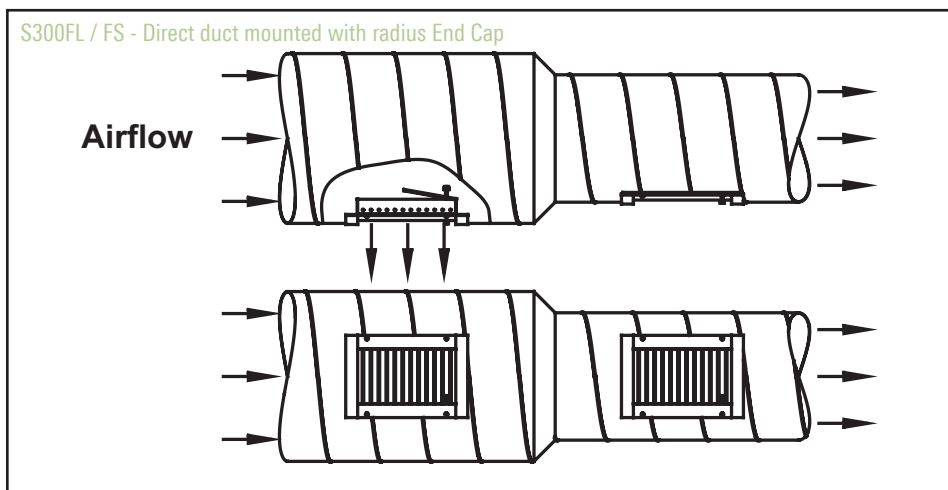
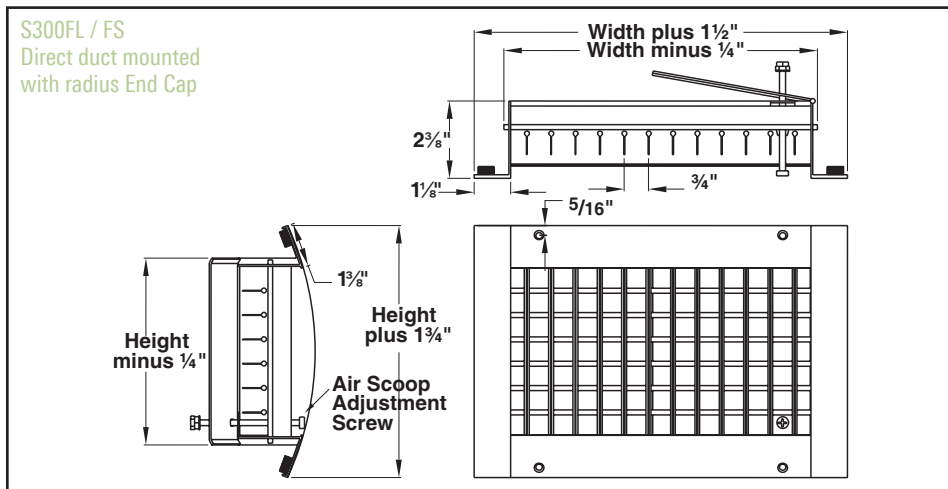
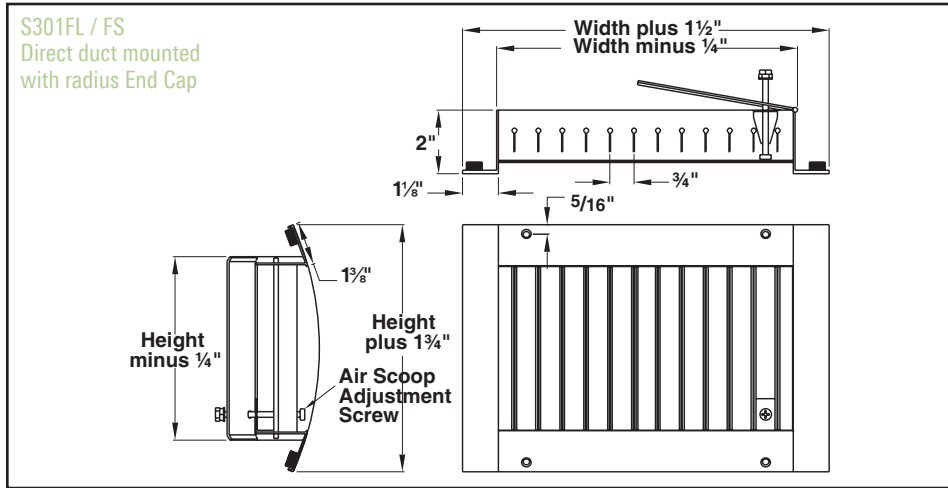

Application Note: For duct velocities up to 800 fpm, the damper/extractor is not required. For duct velocities higher than 800 fpm, the damper/extractor is recommended.

US301 / US300 (FL / FS)

US301FL (Single Deflection)

- 3/4" blade spacing
- Individually adjustable blades
- Universal endcaps multiple duct diameters to avoid installation cost of duct taps
- Blades parallel to the long dimension

US301FS

- Same as US301FL with blades parallel to the short dimension

US300FL (Double Deflection)

- 3/4" blade spacing
- Individually adjustable blades
- Universal endcaps multiple duct diameters to avoid installation cost of duct taps
- Blades parallel to the long dimension

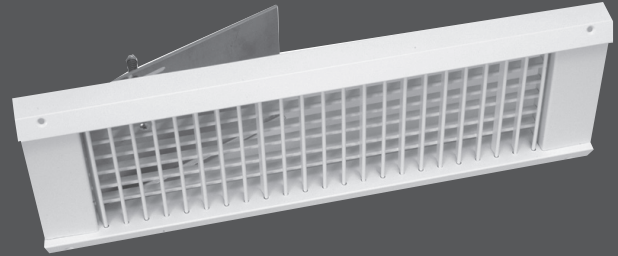

US301 / US300 (FL / FS)

US300FS

- Same as US300FL with blades parallel to the short dimension



duct mounted

AVAILABLE MODELS:

Single Deflection Models:

US301FL
US301FS

Double Deflection Models:

US300FL
US300FS

FINISHES

Standard Finish - #26 White or #34 Clear Anodize.

OVERVIEW

Spiral Grilles mount directly to the duct, eliminating the need for duct taps. They are available in two border styles: S series for radius end cap to match duct diameter, and US (Universal) series which can be used on any duct diameter. Each grille has a gasket to provide a tight seal to the duct.

PRODUCTS INCLUDE

- Material: Aluminum extruded borders and blades
- Countersunk screw holes and curved end caps
- Foam gasketing standard for tight seal
- Optional ASD-Air scoop device



See website for Specifications

US301 / US300 (FL / FS) DIMENSIONS

Height	Min : Max Duct Diameter
3"	10" : 36"
4"	10" : 36"
6"	12" : 36"
8"	20" : 36"
10"	24" : 36"
12"	24" : 36"

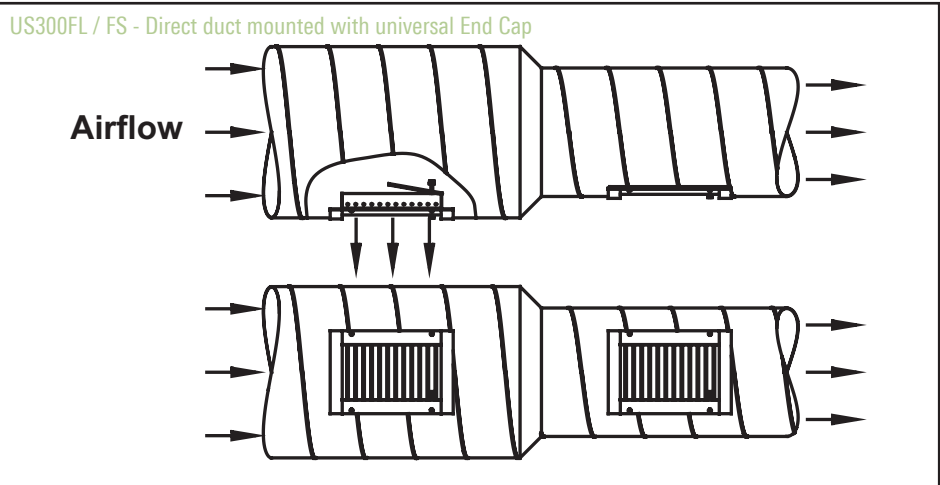
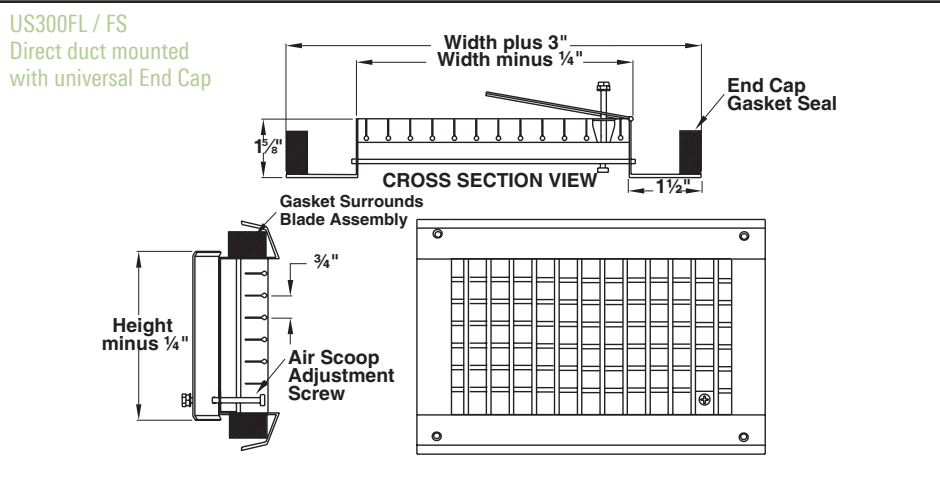
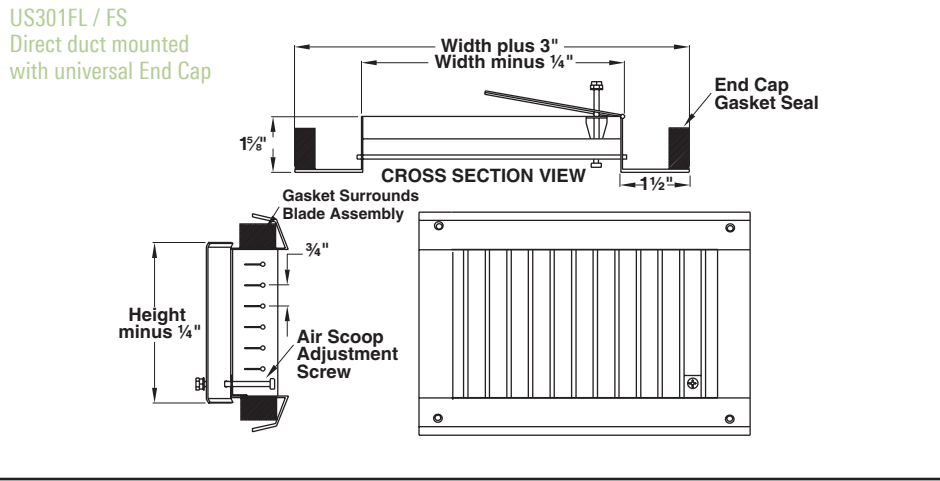

Application Note: For duct velocities up to 800 fpm, the damper/extractor is not required. For duct velocities higher than 800 fpm, the damper/extractor is recommended.

S8F / US8F

S8F

- $\frac{3}{16}$ " perforated holes on $\frac{1}{4}$ " staggered centers
- Radius endcaps match duct to avoid installation cost of duct taps

US8F

- Same as S8F except with universal border allows grille to match multiple duct diameters, save installation cost of duct taps

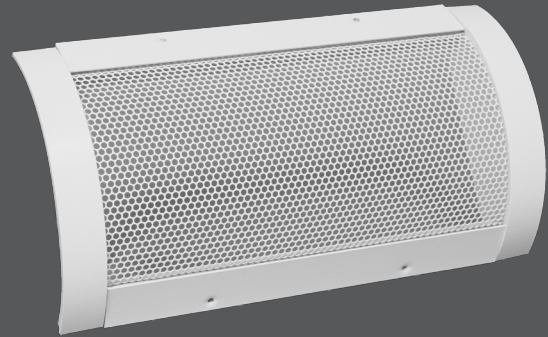

S8F / US8F



duct mounted

AVAILABLE MODELS:

$\frac{3}{16}$ " Perforated Hole Model with Radius End Caps:
S8F

$\frac{3}{16}$ " Perforated Hole Model with Universal End Caps:
US8F

FINISHES

Standard Finish - #26 White or #34 Clear Anodize

OVERVIEW

Spiral Grilles mount directly to the duct, eliminating the need for duct taps. They are available in two border styles: S series for radius end cap to match duct diameter, and US (Universal) series which can be used on any duct diameter. Each grille has a gasket to provide a tight seal to the duct.

PRODUCTS INCLUDE

- Material: Aluminum extended frame and perforated sheet
- Countersunk screw holes with curved border (S8F) or universal duct size border (US8F)
- Foam gasketing standard for tight seal



See website for Specifications

S8F / US8F DIMENSIONS

S8F	
Height	Min : Max Duct Diameter
3"	6" : 36"
4"	8" : 36"
6"	10" : 36"
8"	12" : 36"
10"	14" : 36"
12"	16" : 36"

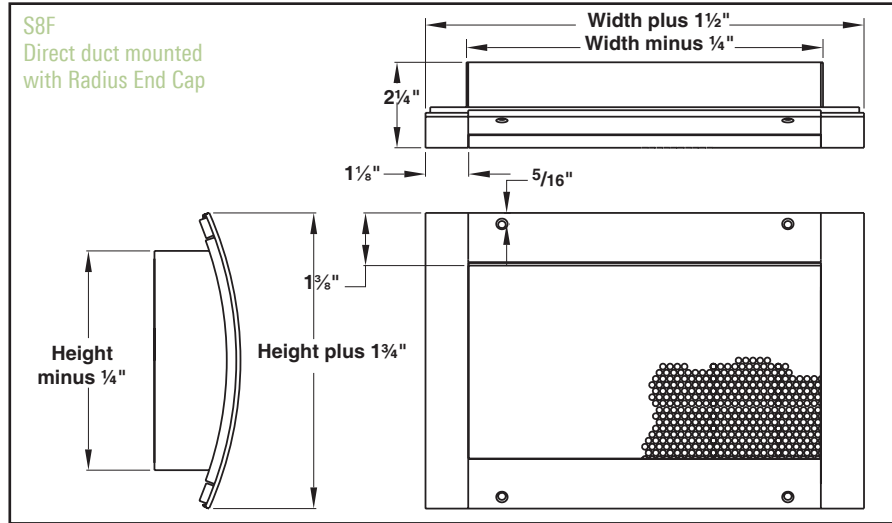

US8F	
Height	Min : Max Duct Diameter
3"	10" : 36"
4"	10" : 36"
6"	12" : 36"
8"	20" : 36"
10"	24" : 36"
12"	24" : 36"

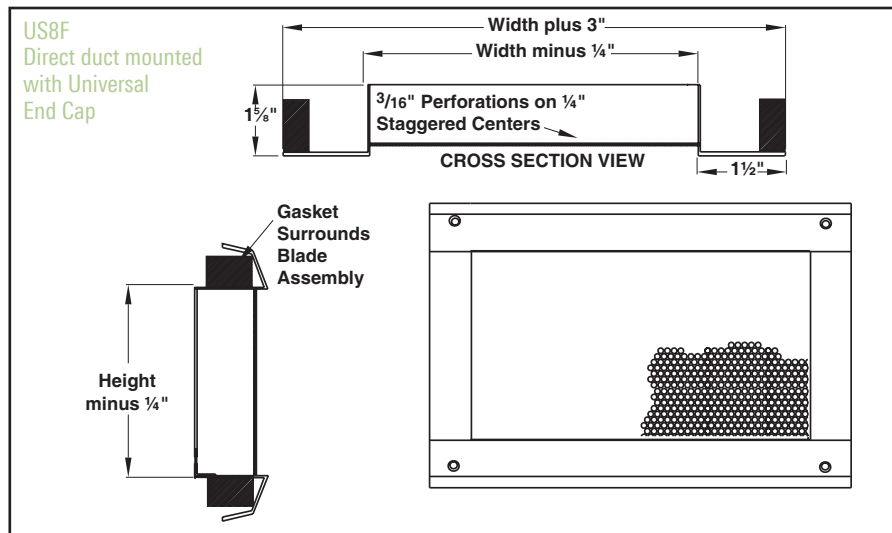

* For Performance Data see 8F

S300F, US300F, S301F AND US301F SUPPLY WITH NO EXTRACTOR
PERFORMANCE BASED ON NOMINAL SIZES SHOWN IN BOLD

Nominal Duct Size (in.)	Nominal Duct Area sq. ft	Core Area sq. ft	Core Velocity, (fpm)		300	400	500	600	700	800	1000	1200	1400
			Velocity Pressure	Pressure	0.006	0.010	0.016	0.022	0.031	0.040	0.062	0.090	0.122
			Total	0°	0.016	0.029	0.046	0.066	0.090	0.117	0.183	0.263	0.358
			Pressure	22.5°	0.018	0.033	0.051	0.074	0.100	0.131	0.204	0.294	0.401
				45°	0.028	0.049	0.077	0.111	0.152	0.198	0.309	0.445	0.606
10x3	0.21	0.14	Airflow, cfm		42	56	70	84	98	112	140	168	196
			NC		-	-	-	14	19	23	29	35	40
			Throw (Ft.)	0°	3-6-8	4-7-10	5-8-11	6-8-12	7-9-13	8-10-14	9-11-15	10-12-17	10-13-18
				22.5°	2-5-6	3-5-7	4-6-8	5-6-9	6-7-10	7-8-11	7-9-12	7-9-13	8-10-14
			45°	1-3-4	2-3-4	2-3-5	3-4-5	3-4-6	4-4-6	4-5-7	4-5-8	5-6-8	
12x3	0.25	0.18	Airflow, cfm		54	72	90	108	126	144	180	216	252
			NC		-	-	-	15	20	24	31	36	41
			Throw (Ft.)	0°	5-7-9	6-8-11	7-9-12	8-9-13	8-10-14	9-11-15	10-12-17	11-13-19	12-14-20
				22.5°	4-5-7	5-6-8	5-7-9	6-7-10	6-8-11	7-8-12	8-9-13	8-10-15	9-11-16
			45°	2-3-4	3-3-5	3-4-5	3-4-6	4-5-7	4-5-7	4-5-8	5-6-9	5-7-9	
10x4 14x3	0.28	0.21	Airflow, cfm		63	84	105	126	147	168	210	252	294
			NC		-	-	-	16	21	25	31	37	41
			Throw (Ft.)	0°	5-7-10	7-8-12	8-9-13	8-10-14	9-11-16	10-12-17	11-13-19	12-14-20	13-16-22
				22.5°	4-6-8	5-6-9	6-7-10	6-8-11	7-9-12	7-9-13	8-10-14	9-11-16	10-12-17
			45°	2-3-5	3-4-5	3-4-6	4-5-7	4-5-7	4-5-8	5-6-8	5-7-9	6-7-10	
16x3 12x4	0.33	0.25	Airflow, cfm		75	100	125	150	175	200	250	300	350
			NC		-	-	-	17	21	25	32	37	42
			Throw (Ft.)	0°	5-8-11	7-9-13	8-10-14	9-11-16	10-12-17	11-13-18	12-14-20	13-16-22	14-17-24
				22.5°	4-6-9	6-7-10	6-8-11	7-9-12	8-9-13	8-10-14	9-11-16	10-12-17	11-13-19
			45°	2-4-5	3-4-6	4-5-6	4-5-7	4-5-8	5-6-8	5-6-9	6-7-10	6-8-11	
18x3 14x4	0.38	0.27	Airflow, cfm		81	108	135	162	189	216	270	324	378
			NC		-	-	-	17	22	26	32	38	42
			Throw (Ft.)	0°	6-8-12	8-9-13	9-11-15	9-12-16	10-13-18	11-13-19	12-15-21	13-16-23	14-18-25
				22.5°	4-6-9	6-7-10	7-8-12	7-9-13	8-10-14	8-10-15	9-12-16	10-13-18	11-14-19
			45°	2-4-5	3-4-6	4-5-7	4-5-7	5-6-8	5-6-9	5-7-10	6-7-10	7-8-11	
10x6 20x3	0.42	0.3	Airflow, cfm		90	120	150	180	210	240	300	360	420
			NC		-	-	-	17	22	26	33	38	43
			Throw (Ft.)	0°	6-9-12	8-10-14	9-11-16	10-12-17	11-13-19	12-14-20	13-16-22	14-17-24	15-19-26
				22.5°	5-7-9	6-8-11	7-9-12	8-9-13	8-10-14	9-11-15	10-12-17	11-13-19	12-14-20
			45°	3-4-5	4-4-6	4-5-7	4-5-8	5-6-8	5-6-9	6-7-10	6-8-11	7-8-12	
16x4 22x3	0.44	0.34	Airflow, cfm		102	136	170	204	238	272	340	408	476
			NC		-	-	-	18	23	27	33	39	43
			Throw (Ft.)	0°	6-9-13	9-11-15	10-12-17	11-13-18	11-14-20	12-15-21	14-17-24	15-18-26	16-20-28
				22.5°	5-7-10	7-8-12	8-9-13	8-10-14	9-11-15	9-12-16	11-13-18	12-14-20	13-15-22
			45°	3-4-6	4-5-7	4-5-8	5-6-8	5-6-9	6-7-10	6-8-11	7-8-12	7-9-13	
24x3 12x6 18x4 26x3	0.50	0.39	Airflow, cfm		117	156	195	234	273	312	390	468	546
			NC		-	-	-	18	23	27	34	39	44
			Throw (Ft.)	0°	7-10-14	9-11-16	10-13-18	11-14-20	12-15-21	13-16-23	15-18-25	16-20-28	17-21-30
				22.5°	5-8-11	7-9-12	8-10-14	9-11-15	10-12-16	10-12-18	11-14-20	12-15-22	13-16-23
			45°	3-4-6	4-5-7	5-6-8	5-6-9	6-7-10	6-7-10	7-8-11	7-9-13	8-10-14	
14x6 20x4 28x3	0.56	0.43	Airflow, cfm		129	172	215	258	301	344	430	516	602
			NC		-	-	-	19	24	27	34	40	44
			Throw (Ft.)	0°	7-10-15	10-12-17	11-13-19	12-15-21	13-16-22	14-17-24	15-19-27	17-21-29	18-22-32
				22.5°	5-8-11	8-9-13	8-10-15	9-11-16	10-12-17	11-13-18	12-15-21	13-16-23	14-17-24
			45°	3-5-7	4-5-8	5-6-8	5-7-9	6-7-10	6-8-11	7-8-12	8-9-13	8-10-14	
22x4 30x3	0.61	0.48	Airflow, cfm		144	192	240	288	336	384	480	576	672
			NC		-	-	-	19	24	28	35	40	45
			Throw (Ft.)	0°	7-11-15	10-13-18	12-14-20	13-15-22	14-17-24	15-18-25	16-20-28	18-22-31	19-24-33
				22.5°	6-8-12	8-10-14	9-11-15	10-12-17	11-13-18	11-14-20	13-15-22	14-17-24	15-18-26
			45°	3-5-7	5-6-8	5-6-9	6-7-10	6-8-11	7-8-11	7-9-13	8-10-14	9-11-15	
32x3 24x4 16x6 12x8	0.67	0.52	Airflow, cfm		156	208	260	312	364	416	520	624	728
			NC		-	-	-	20	24	28	35	40	45
			Throw (Ft.)	0°	8-11-16	11-13-19	12-15-21	13-16-23	14-17-25	15-19-26	17-21-29	19-23-32	20-25-35
				22.5°	6-9-12	8-10-14	9-11-16	10-12-18	11-13-19	12-14-20	13-16-23	14-18-25	16-19-27
			45°	3-5-7	5-6-8	5-7-9	6-7-10	6-8-11	7-8-12	8-9-13	8-10-14	9-11-16	

- Performance data based on actual application conditions - direct duct mounted grille, 90° to airflow with no ceiling
- Terminal velocities are shown for 150, 100 and 50 fpm. Throw data is without a ceiling.
- All pressures are given in inches of water
- 0°, 22.5° and 45° represent blade deflection angles

- Performance data based on duct sizes in bold, the performance varies slightly for duct sizes not shown in bold
- When selecting larger supply grilles for cooling purposes, see the topic, "Procedure to Obtain Catalog Throw Data" in the section, Engineering Guidelines of this catalog

S300F, US300F, S301F AND US301F SUPPLY WITH NO EXTRACTOR
PERFORMANCE BASED ON NOMINAL SIZES SHOWN IN BOLD

Nominal Duct Size (in.)	Nominal Duct Area sq. ft	Core Area sq. ft	Core Velocity, (fpm)		300	400	500	600	700	800	1000	1200	1400
			Velocity Pressure		0.006	0.010	0.016	0.022	0.031	0.040	0.062	0.090	0.122
			Total Pressure	0°	0.016	0.029	0.046	0.066	0.090	0.117	0.183	0.263	0.358
			22.5°	0.018	0.033	0.051	0.074	0.100	0.131	0.204	0.294	0.401	
			45°	0.028	0.049	0.077	0.111	0.152	0.198	0.309	0.445	0.606	
26x4 10x10 34x3	0.69	0.59	Airflow, cfm		177	236	295	354	413	472	590	708	826
			NC		-	-	15	20	25	29	35	41	46
			Throw (Ft.)	0°	8-12-17	11-14-20	13-16-22	14-17-24	15-18-26	16-20-28	18-22-31	20-24-34	21-26-37
				22.5°	6-9-13	9-11-15	10-12-17	11-13-19	12-14-20	13-15-22	14-17-24	15-19-27	17-20-29
			45°	4-5-8	5-6-9	6-7-10	6-8-11	7-8-12	7-9-13	8-10-14	9-11-15	10-12-17	
28x4 18x6 36x3	0.75	0.63	Airflow, cfm		189	252	315	378	441	504	630	756	882
			NC		-	-	15	20	25	29	36	41	46
			Throw (Ft.)	0°	8-13-18	12-14-20	13-16-23	14-18-25	16-19-27	17-20-29	19-23-32	20-25-35	22-27-38
				22.5°	7-10-14	9-11-16	10-13-18	11-14-19	12-15-21	13-16-22	14-18-25	16-19-27	17-21-30
			45°	4-6-8	5-7-9	6-7-10	7-8-11	7-9-12	8-9-13	8-10-15	9-11-16	10-12-17	
20x6 12x10 30x4	0.83	0.66	Airflow, cfm		198	264	330	396	462	528	660	792	924
			NC		-	-	15	21	25	29	36	41	46
			Throw (Ft.)	0°	9-13-18	12-15-21	13-17-23	15-18-26	16-20-28	17-21-30	19-23-33	21-26-36	23-28-39
				22.5°	7-10-14	9-11-16	10-13-18	11-14-20	12-15-21	13-16-23	15-18-26	16-20-28	18-21-30
			45°	4-6-8	5-7-9	6-7-10	7-8-12	7-9-12	8-9-13	9-11-15	9-12-16	10-12-18	
32x4	0.89	0.71	Airflow, cfm		213	284	355	426	497	568	710	852	994
			NC		-	-	16	21	26	30	36	42	46
			Throw (Ft.)	0°	9-13-19	13-15-22	14-17-24	15-19-27	17-20-29	18-22-31	20-24-34	22-27-38	23-29-41
				22.5°	7-10-15	10-12-17	11-13-19	12-15-21	13-16-22	14-17-24	15-19-27	17-21-29	18-22-31
			45°	4-6-8	6-7-10	6-8-11	7-8-12	7-9-13	8-10-14	9-11-15	10-12-17	11-13-18	
24x6 18x8 12x12 36x4	1.00	0.88	Airflow, cfm		264	352	440	528	616	704	880	1056	1232
			NC		-	-	16	22	26	30	37	43	47
			Throw (Ft.)	0°	10-15-21	14-17-24	16-19-27	17-21-30	18-23-32	20-24-34	22-27-38	24-30-42	26-32-45
				22.5°	8-11-16	11-13-19	12-15-21	13-16-23	14-18-25	15-19-26	17-21-30	19-23-32	20-25-35
			45°	4-7-9	6-8-11	7-9-12	8-9-13	8-10-14	9-11-15	10-12-17	11-13-19	12-14-20	
30x6 18x10	1.25	1.11	Airflow, cfm		333	444	555	666	777	888	1110	1332	1554
			NC		-	11	17	23	27	31	38	44	48
			Throw (Ft.)	0°	11-17-23	16-19-27	18-21-30	19-23-33	21-25-36	22-27-38	25-30-43	27-33-47	29-36-51
				22.5°	9-13-18	12-15-21	14-17-23	15-18-26	16-20-28	17-21-30	19-23-33	21-26-36	23-28-39
			45°	5-7-11	7-9-12	8-10-14	9-11-15	9-11-16	10-12-17	11-14-19	12-15-21	13-16-23	
36x6 18x12	1.50	1.35	Airflow, cfm		405	540	675	810	945	1080	1350	1620	1890
			NC		-	12	18	24	28	32	39	44	49
			Throw (Ft.)	0°	12-18-26	17-21-30	19-24-33	21-26-37	23-28-40	24-30-42	27-33-47	30-37-52	32-40-56
				22.5°	10-14-20	13-16-23	15-18-26	16-20-28	18-22-31	19-23-33	21-26-37	23-28-40	25-31-43
			45°	6-8-12	8-10-13	9-11-15	10-12-16	10-13-18	11-13-19	12-15-21	13-16-23	15-18-25	
30x8 24x10	1.67	1.49	Airflow, cfm		447	596	745	894	1043	1192	1490	1788	2086
			NC		-	12	19	24	29	33	39	45	49
			Throw (Ft.)	0°	13-19-27	18-22-31	20-25-35	22-27-38	24-29-42	26-31-44	29-35-50	31-38-54	34-42-59
				22.5°	10-15-21	14-17-24	16-19-27	17-21-30	19-23-32	20-24-34	22-27-38	24-30-42	26-32-46
			45°	6-9-12	8-10-14	9-11-16	10-12-17	11-13-19	12-14-20	13-16-22	14-17-24	15-19-26	
36x8 24x12	2.00	1.82	Airflow, cfm		546	728	910	1092	1274	1456	1820	2184	2548
			NC		-	13	19	25	30	34	40	46	50
			Throw (Ft.)	0°	14-21-30	20-25-35	22-27-39	25-30-43	27-32-46	28-35-49	32-39-55	35-43-60	38-46-65
				22.5°	11-16-23	16-19-27	17-21-30	19-23-33	21-25-36	22-27-38	25-30-43	27-33-47	29-36-50
			45°	6-10-14	9-11-16	10-12-17	11-14-19	12-15-21	13-16-22	14-17-25	16-19-27	17-21-29	
36x10 30x12	2.50	2.29	Airflow, cfm		687	916	1145	1374	1603	1832	2290	2748	3206
			NC		-	14	20	26	30	34	41	47	51
			Throw (Ft.)	0°	16-24-34	22-28-39	25-31-44	28-34-48	30-36-52	32-39-55	36-44-62	39-48-67	42-52-73
				22.5°	12-18-26	17-21-30	19-24-34	21-26-37	23-28-40	25-30-43	28-34-48	30-37-52	33-40-56
			45°	7-11-15	10-12-18	11-14-20	12-15-21	13-16-23	14-18-25	16-20-28	18-21-30	19-23-33	
36x12	3.00	2.75	Airflow, cfm		825	1100	1375	1650	1925	2200	2750	3300	3850
			NC		-	15	21	27	31	35	42	47	52
			Throw (Ft.)	0°	18-26-37	25-30-43	28-34-48	30-37-52	33-40-56	35-43-60	39-48-67	43-52-74	46-56-80
				22.5°	14-20-29	19-23-33	21-26-37	23-29-41	25-31-44	27-33-47	30-37-52	33-41-57	36-44-62
			45°	8-12-17	11-14-19	12-15-21	14-17-24	15-18-25	16-19-27	18-21-30	19-24-33	21-25-36	

- Performance data based on actual application conditions - direct duct mounted grille, 90° to airflow with no ceiling
- Terminal velocities are shown for 150, 100 and 50 fpm. Throw data is without a ceiling.
- All pressures are given in inches of water
- 0°, 22.5° and 45° represent blade deflection angles
- Performance data based on duct sizes in bold, the performance varies slightly for duct sizes not shown in bold
- When selecting larger supply grilles for cooling purposes, see the topic, "Procedure to Obtain Catalog Throw Data" in the section, Engineering Guidelines of this catalog

S300F, US300F, S301F AND US301F SUPPLY WITH EXTRACTOR SET AT 45° ANGLE
PERFORMANCE BASED ON NOMINAL SIZES SHOWN IN BOLD

Nominal Duct Size (in.)	Nominal Duct Area sq. ft	Core Area sq. ft	Core Velocity, (fpm)		300	400	500	600	700	800	1000	1200
			Velocity Pressure		0.006	0.010	0.016	0.022	0.031	0.040	0.062	0.090
			Total Pressure	0°	0.033	0.058	0.091	0.132	0.179	0.234	0.365	0.526
			22.5°	0.037	0.065	0.102	0.147	0.200	0.262	0.409	0.589	
			45°	0.056	0.099	0.155	0.223	0.303	0.396	0.618	0.891	
10x3	0.21	0.14	Airflow, cfm		42	56	70	84	98	112	140	168
			NC		-	-	13	18	23	27	33	39
			Throw (Ft.)	0°	3-6-8	4-7-10	5-8-11	6-8-12	7-9-13	8-10-14	9-11-15	10-12-17
			22.5°	2-5-6	3-5-7	4-6-8	5-6-9	5-7-10	6-7-11	7-8-12	7-9-13	
			45°	1-3-4	2-3-4	2-3-5	3-4-5	3-4-6	4-4-6	4-5-7	4-5-8	
12x3	0.25	0.18	Airflow, cfm		54	72	90	108	126	144	180	216
			NC		-	-	14	19	24	28	35	40
			Throw (Ft.)	0°	5-7-9	6-8-11	7-9-12	8-9-13	8-10-14	9-11-15	10-12-17	11-13-19
			22.5°	4-5-7	5-6-8	5-7-9	6-7-10	6-8-11	7-8-12	8-9-13	8-10-15	
			45°	2-3-4	3-3-5	3-4-5	3-4-6	4-5-7	4-5-7	4-5-8	5-6-9	
10x4 14x3	0.28	0.21	Airflow, cfm		63	84	105	126	147	168	210	252
			NC		-	-	14	20	25	29	35	41
			Throw (Ft.)	0°	5-7-10	7-8-12	8-9-13	8-10-14	9-11-16	10-12-17	11-13-19	12-14-20
			22.5°	4-6-8	5-6-9	6-7-10	6-8-11	7-9-12	7-9-13	8-10-14	9-11-16	
			45°	2-3-5	3-4-5	3-4-6	4-5-7	4-5-7	4-5-8	5-6-8	5-7-9	
16x3 12x4	0.33	0.25	Airflow, cfm		75	100	125	150	175	200	250	300
			NC		-	-	15	21	25	29	36	41
			Throw (Ft.)	0°	5-8-11	7-9-13	8-10-14	9-11-16	10-12-17	11-13-18	12-14-20	13-16-22
			22.5°	4-6-9	6-7-10	6-8-11	7-9-12	8-9-13	8-10-14	9-11-16	10-12-17	
			45°	2-4-5	3-4-6	4-5-6	4-5-7	4-5-8	5-6-8	5-6-9	6-7-10	
18x3 14x4	0.38	0.27	Airflow, cfm		81	108	135	162	189	216	270	324
			NC		-	-	16	21	26	30	36	42
			Throw (Ft.)	0°	6-8-12	8-9-13	9-11-15	9-12-16	10-13-18	11-13-19	12-15-21	13-16-23
			22.5°	4-6-9	6-7-10	7-8-12	7-9-13	8-10-14	8-10-15	9-12-16	10-13-18	
			45°	2-4-5	3-4-6	4-5-7	4-5-7	5-6-8	5-6-9	5-7-10	6-7-10	
10x6 20x3	0.42	0.3	Airflow, cfm		90	120	150	180	210	240	300	360
			NC		-	-	16	21	26	30	37	42
			Throw (Ft.)	0°	6-9-12	8-10-14	9-11-16	10-12-17	11-13-19	12-14-20	13-16-22	14-17-24
			22.5°	5-7-9	6-8-11	7-9-12	8-9-13	8-10-14	9-11-15	10-12-17	11-13-19	
			45°	3-4-5	4-4-6	4-5-7	4-5-8	5-6-8	5-6-9	6-7-10	6-8-11	
16x4 22x3	0.44	0.34	Airflow, cfm		102	136	170	204	238	272	340	408
			NC		-	-	16	22	27	31	37	43
			Throw (Ft.)	0°	6-9-13	9-11-15	10-12-17	11-13-18	11-14-20	12-15-21	14-17-24	15-18-26
			22.5°	5-7-10	7-8-12	8-9-13	8-10-14	9-11-15	9-12-16	11-13-18	12-14-20	
			45°	3-4-6	4-5-7	4-5-8	5-6-8	5-6-9	6-7-10	6-8-11	7-8-12	
24x3 12x6 18x4 26x3	0.50	0.39	Airflow, cfm		117	156	195	234	273	312	390	468
			NC		-	-	17	22	27	31	38	43
			Throw (Ft.)	0°	7-10-14	9-11-16	10-13-18	11-14-20	12-15-21	13-16-23	15-18-25	16-20-28
			22.5°	5-8-11	7-9-12	8-10-14	9-11-15	10-12-16	10-12-18	11-14-20	12-15-22	
			45°	3-4-6	4-5-7	5-6-8	5-6-9	6-7-10	6-7-10	7-8-11	7-9-13	
14x6 20x4 28x3	0.56	0.43	Airflow, cfm		129	172	215	258	301	344	430	516
			NC		-	11	17	23	28	31	38	44
			Throw (Ft.)	0°	7-10-15	10-12-17	11-13-19	12-15-21	13-16-22	14-17-24	15-19-27	17-21-29
			22.5°	5-8-11	8-9-13	8-10-15	9-11-16	10-12-17	11-13-18	12-15-21	13-16-23	
			45°	3-5-7	4-5-8	5-6-8	5-7-9	6-7-10	6-8-11	7-8-12	8-9-13	
22x4 30x3	0.61	0.48	Airflow, cfm		144	192	240	288	336	384	480	576
			NC		-	11	18	23	28	32	39	44
			Throw (Ft.)	0°	7-11-15	10-13-18	12-14-20	13-15-22	14-17-24	15-18-25	16-20-28	18-22-31
			22.5°	6-8-12	8-10-14	9-11-15	10-12-17	11-13-18	11-14-20	13-15-22	14-17-24	
			45°	3-5-7	5-6-8	5-6-9	6-7-10	6-8-11	7-8-11	7-9-13	8-10-14	
32x3 24x4 16x6 12x8	0.67	0.52	Airflow, cfm		156	208	260	312	364	416	520	624
			NC		-	12	18	24	28	32	39	44
			Throw (Ft.)	0°	8-11-16	11-13-19	12-15-21	13-16-23	14-17-25	15-19-26	17-21-29	19-23-32
			22.5°	6-9-12	8-10-14	9-11-16	10-12-18	11-13-19	12-14-20	13-16-23	14-18-25	
			45°	3-5-7	5-6-8	5-7-9	6-7-10	6-8-11	7-8-12	8-9-13	8-10-14	

- Performance data based on actual application conditions - direct duct mounted grille, 90° to airflow with no ceiling
- Terminal velocities are shown for 150, 100 and 50 fpm. Throw data is without a ceiling.
- All pressures are given in inches of water
- 0°, 22.5° and 45° represent blade deflection angles
- Performance data based on duct sizes in bold, the performance varies slightly for duct sizes not shown in bold
- When selecting larger supply grilles for cooling purposes, see the topic, "Procedure to Obtain Catalog Throw Data" in the section, Engineering Guidelines of this catalog

S300F, US300F, S301F AND US301F SUPPLY WITH EXTRACTOR SET AT 45° ANGLE
PERFORMANCE BASED ON NOMINAL SIZES SHOWN IN BOLD.

Nominal Duct Size (in.)	Nominal Duct Area sq. ft	Core Area sq. ft	Core Velocity, (fpm)		300	400	500	600	700	800	1000	1200
			Velocity Pressure		0.006	0.010	0.016	0.022	0.031	0.040	0.062	0.090
			Total Pressure	0°	0.033	0.058	0.091	0.132	0.179	0.234	0.365	0.526
			22.5°	0.037	0.065	0.102	0.147	0.200	0.262	0.409	0.589	
			45°	0.056	0.099	0.155	0.223	0.303	0.396	0.618	0.891	
26x4 10x10 34x3	0.69	0.59	Airflow, cfm		177	236	295	354	413	472	590	708
			NC		-	12	19	24	29	33	39	45
			Throw (Ft.)	0°	8-12-17	11-14-20	13-16-22	14-17-24	15-18-26	16-20-28	18-22-31	20-24-34
			22.5°	6-9-13	9-11-15	10-12-17	11-13-19	12-14-20	13-15-22	14-17-24	15-19-27	
			45°	4-5-8	5-6-9	6-7-10	6-8-11	7-8-12	7-9-13	8-10-14	9-11-15	
28x4 18x6 36x3	0.75	0.63	Airflow, cfm		189	252	315	378	441	504	630	756
			NC		-	12	19	24	29	33	40	45
			Throw (Ft.)	0°	8-13-18	12-14-20	13-16-23	14-18-25	16-19-27	17-20-29	19-23-32	20-25-35
			22.5°	7-10-14	9-11-16	10-13-18	11-14-19	12-15-21	13-16-22	14-18-25	16-19-27	
			45°	4-6-8	5-7-9	6-7-10	7-8-11	7-9-12	8-9-13	8-10-15	9-11-16	
20x6 12x10 30x4	0.83	0.66	Airflow, cfm		198	264	330	396	462	528	660	792
			NC		-	13	19	25	29	33	40	45
			Throw (Ft.)	0°	9-13-18	12-15-21	13-17-23	15-18-26	16-20-28	17-21-30	19-23-33	21-26-36
			22.5°	7-10-14	9-11-16	10-13-18	11-14-20	12-15-21	13-16-23	15-18-26	16-20-28	
			45°	4-6-8	5-7-9	6-7-11	7-8-12	7-9-12	8-9-13	9-11-15	9-12-16	
32x4	0.89	0.71	Airflow, cfm		213	284	355	426	497	568	710	852
			NC		-	13	20	25	30	34	40	46
			Throw (Ft.)	0°	9-13-19	13-15-22	14-17-24	15-19-27	17-20-29	18-22-31	20-24-34	22-27-38
			22.5°	7-10-15	10-12-17	11-13-19	12-15-21	13-16-22	14-17-24	15-19-27	17-21-29	
			45°	4-6-8	6-7-10	6-8-11	7-8-12	7-9-13	8-10-14	9-11-15	10-12-17	
24x6 18x8 12x12 36x4	1.00	0.88	Airflow, cfm		264	352	440	528	616	704	880	1056
			NC		-	14	20	26	30	34	41	47
			Throw (Ft.)	0°	10-15-21	14-17-24	16-19-27	17-21-30	18-23-32	20-24-34	22-27-38	24-30-42
			22.5°	8-11-16	11-13-19	12-15-21	13-16-23	14-18-25	15-19-26	17-21-30	19-23-32	
			45°	4-7-9	6-8-11	7-9-12	8-9-13	8-10-14	9-11-15	10-12-17	11-13-19	
30x6 18x10	1.25	1.11	Airflow, cfm		333	444	555	666	777	888	1110	1332
			NC		-	15	21	27	31	35	42	48
			Throw (Ft.)	0°	11-17-23	16-19-27	18-21-30	19-23-33	21-25-36	22-27-38	25-30-43	27-33-47
			22.5°	9-13-18	12-15-21	14-17-23	15-18-26	16-20-28	17-21-30	19-23-33	21-26-36	
			45°	5-7-11	7-9-12	8-10-14	9-11-15	9-11-16	10-12-17	11-14-19	12-15-21	
36x6 18x12	1.50	1.35	Airflow, cfm		405	540	675	810	945	1080	1350	1620
			NC		-	16	22	28	32	36	43	48
			Throw (Ft.)	0°	12-18-26	17-21-30	19-24-33	21-26-37	23-28-40	24-30-42	27-33-47	30-37-52
			22.5°	10-14-20	13-16-23	15-18-26	16-20-28	18-22-31	19-23-33	21-26-37	23-28-40	
			45°	6-8-12	8-10-13	9-11-15	10-12-16	10-13-18	11-13-19	12-15-21	13-16-23	
30x8 24x10	1.67	1.49	Airflow, cfm		447	596	745	894	1043	1192	1490	1788
			NC		-	16	23	28	33	37	43	49
			Throw (Ft.)	0°	13-19-27	18-22-31	20-25-35	22-27-38	24-29-42	26-31-44	29-35-50	31-38-54
			22.5°	10-15-21	14-17-24	16-19-27	17-21-30	19-23-32	20-24-34	22-27-38	24-30-42	
			45°	6-9-12	8-10-14	9-11-16	10-12-17	11-13-19	12-14-20	13-16-22	14-17-24	
36x8 24x12	2.00	1.82	Airflow, cfm		546	728	910	1092	1274	1456	1820	2184
			NC		-	17	23	29	34	38	44	50
			Throw (Ft.)	0°	14-21-30	20-25-35	22-27-39	25-30-43	27-32-46	28-35-49	32-39-55	35-43-60
			22.5°	11-16-23	16-19-27	17-21-30	19-23-33	21-25-36	22-27-38	25-30-43	27-33-47	
			45°	6-10-14	9-11-16	10-12-17	11-14-19	12-15-21	13-16-22	14-17-25	16-19-27	
36x10 30x12	2.50	2.29	Airflow, cfm		687	916	1145	1374	1603	1832	2290	2748
			NC		-	18	24	30	34	38	45	51
			Throw (Ft.)	0°	16-24-34	22-28-39	25-31-44	28-34-48	30-36-52	32-39-55	36-44-62	39-48-67
			22.5°	12-18-26	17-21-30	19-24-34	21-26-37	23-28-40	25-30-43	28-34-48	30-37-52	
			45°	7-11-15	10-12-18	11-14-20	12-15-21	13-16-23	14-18-25	16-20-28	18-21-30	
36x12	3.00	2.75	Airflow, cfm		825	1100	1375	1650	1925	2200	2750	3300
			NC		-	19	25	31	35	39	46	51
			Throw (Ft.)	0°	18-26-37	25-30-43	28-34-48	30-37-52	33-40-56	35-43-60	39-48-67	43-52-74
			22.5°	14-20-29	19-23-33	21-26-37	23-29-41	25-31-44	27-33-47	30-37-52	33-41-57	
			45°	8-12-17	11-14-19	12-15-21	14-17-24	15-18-25	16-19-27	18-21-30	19-24-33	

- Performance data based on actual application conditions - direct duct mounted grille, 90° to airflow with no ceiling
- Terminal velocities are shown for 150, 100 and 50 fpm. Throw data is without a ceiling.
- All pressures are given in inches of water
- 0°, 22.5° and 45° represent blade deflection angles
- Performance data based on duct sizes in bold, the performance varies slightly for duct sizes not shown in bold
- When selecting larger supply grilles for cooling purposes, see the topic, "Procedure to Obtain Catalog Throw Data" in the section, Engineering Guidelines of this catalog

T-700 (L / S)

T-700L

- Sight proof
- Used in doors and partitions
- Included v-blades block vision and provide extra strength
- 20-gauge steel blades
- Blades parallel to the long dimension

T-700S

- Same as T-700L with blades parallel to the short dimension

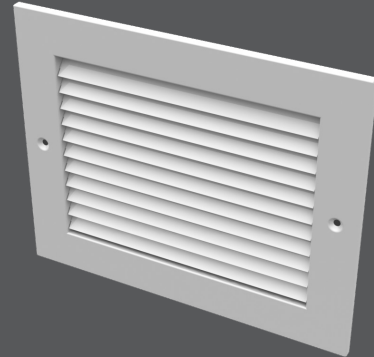

T-700 (L / S)



metric sizes

doors / partitions

sight proof design



See website for Specifications

AVAILABLE MODELS:

T-700L
T-700S

FINISH

Standard Finish - #26 White

OVERVIEW

Steel

Titus Door return grilles are great for use in doors and partitions. They offer a large free are for great performance yet have a sight proof design. Options include steel or aluminum construction and an auxiliary frame for the reverse side.

PRODUCTS INCLUDE

- Available Border Types:
 - #1 - Surface Mount
 - #7 - Channel Frame
- Countersunk Screw Holes
- #8 x 1 1/4" long Phillips Flat Head Sheet Metal Screws, Painted White

DIMENSIONS

Redefine your comfort zone™ | www.titus-hvac.com

T-700 (L / S) DIMENSIONS

Border Type 1 / Surface Mount

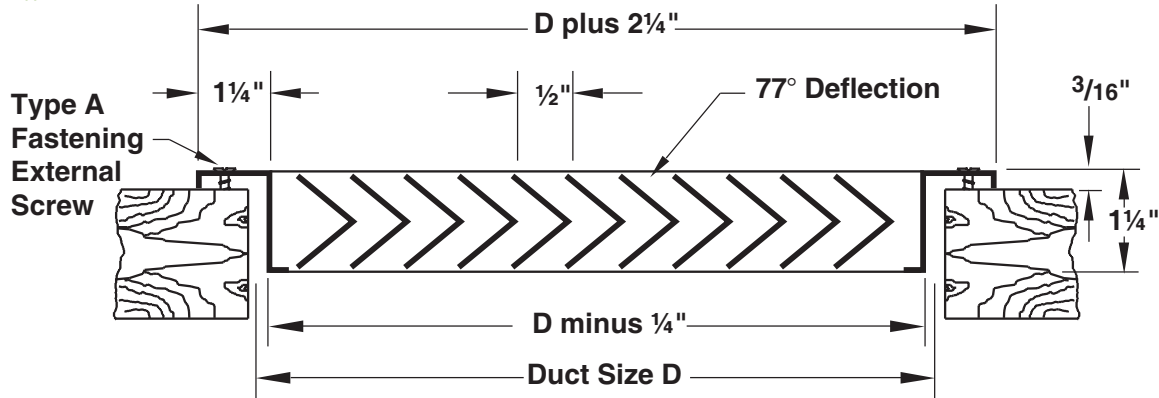

Available sizes (D" x D") Border Type 1 are 6 x 4 inches through 30 x 30 inches in 1" increments

Border Type 7 / Channel Frame

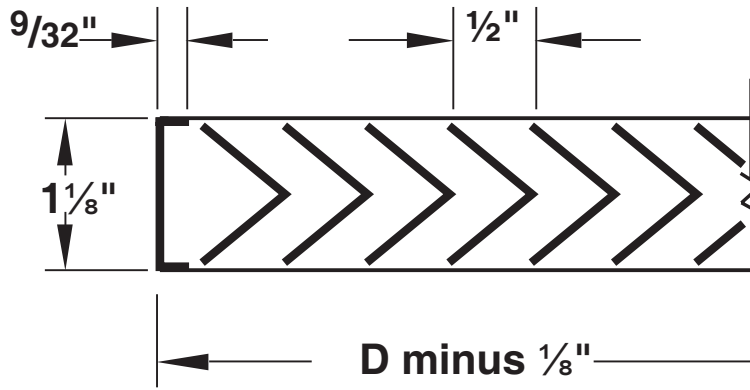

Available sizes (D" x D") Border Type 1 are 6 x 4 inches through 30 x 30 inches in 1" increments

Auxiliary Frame

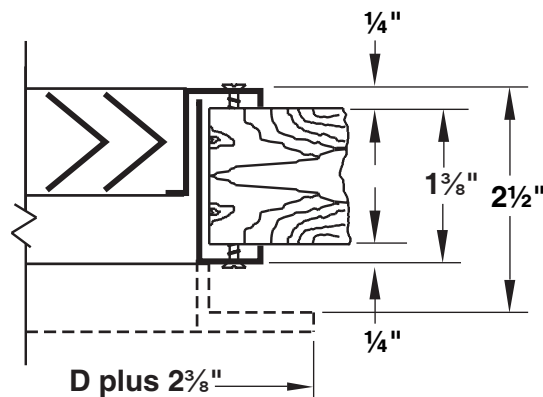

Available sizes (D" x D") Border Type 1 are 6 x 4 inches through 30 x 30 inches in 1" increments

All dimensions are in inches

CT-700 (L / S)

CT-700L

- Sight proof
- Used in doors and partitions
- Included v-blades block vision and provide extra strength
- Aluminum blades
- Blades parallel to the long dimension

CT-700S

- Same as T-700L with blades parallel to the short dimension

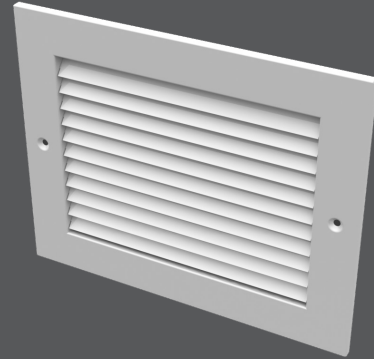

CT-700 (L / S)



metric sizes

doors / partitions

sight proof design



See website for Specifications

AVAILABLE MODELS:

CT-700L
CT-700S

FINISH

Standard Finish - #26 White

OVERVIEW

Aluminum

Titus Door return grilles are great for use in doors and partitions. They offer a large free are for great performance yet have a sight proof design. Options include steel or aluminum construction and an auxiliary frame for the reverse side.

PRODUCTS INCLUDE

- Available Border Types:
 - #1 - Surface Mount
 - Countersunk Screw Holes
- #8 x 1¼" long Phillips Flat Head Sheet Metal Screws, Painted White

DIMENSIONS

CT-700 (L / S) DIMENSIONS

Border Type 1 / Surface Mount

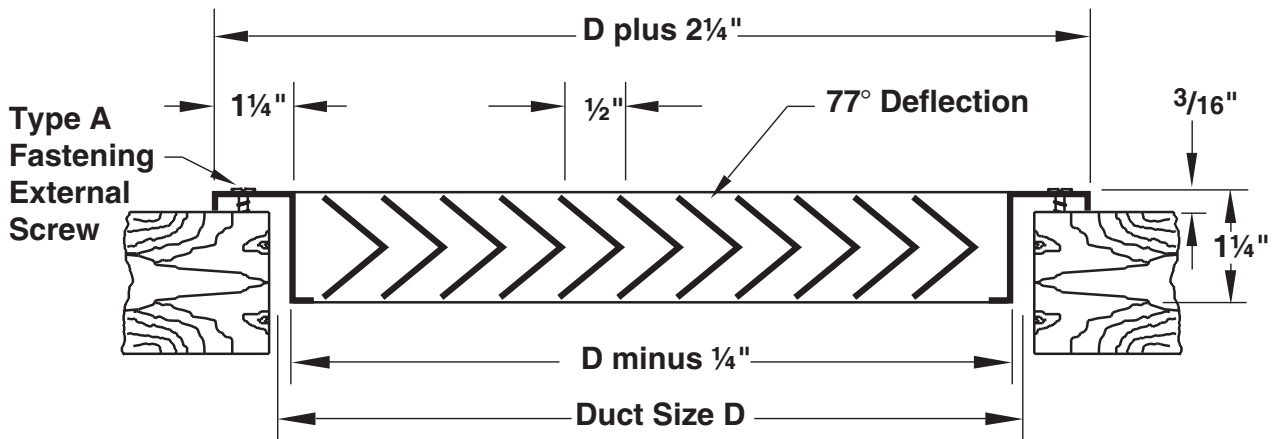

Available sizes (D" x D") Border Type 1 are 6 x 4 inches through 30 x 30 inches in 1" increments

Auxiliary Frame

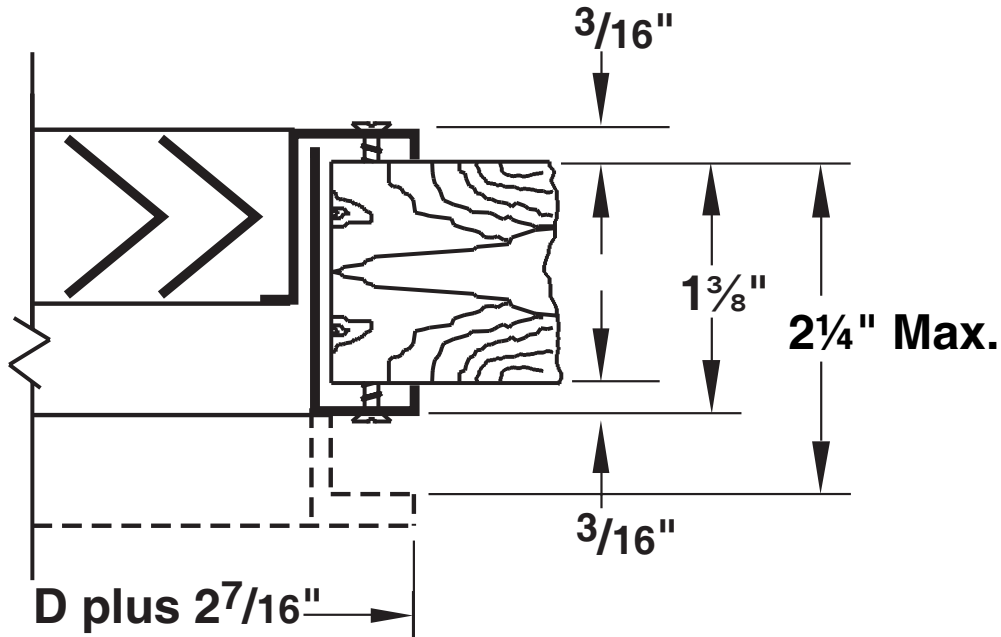

Available sizes (D" x D") Border Type 1 are 6 x 4 inches through 30 x 30 inches in 1" increments

T-700 AND CT-700 DOOR GRILLES
PERFORMANCE BASED ON NOMINAL SIZES SHOWN IN BOLD

Nominal Duct Size (in)	Nominal Duct Area sq. ft	Core Area sq. ft	Core Velocity Velocity Pressure CT-700 Static Pressure T-700 Static Pressure	NC 20			NC 30				NC 40		
				200	250	300	350	400	450	500	550	600	
				0.003	0.004	0.006	0.008	0.010	0.013	0.016	0.019	0.022	
6x6	0.25	0.19	Airflow, cfm	38	48	57	67	76	86	95	105	114	
			NC (Noise Criteria)	15	20	24	27	30	32	34	36	38	
8x6	0.33	0.26	Airflow, cfm	52	65	78	91	104	117	160	143	156	
			NC (Noise Criteria)	16	21	25	28	31	33	36	38	39	
10x6	0.42	0.34	Airflow, cfm	68	85	102	119	136	153	170	187	204	
			NC (Noise Criteria)	18	22	26	29	32	35	37	39	41	
8x8	0.44	0.37	Airflow, cfm	74	93	111	130	148	167	185	204	222	
			NC (Noise Criteria)	18	23	26	30	32	35	37	39	41	
12x6	0.50	0.41	Airflow, cfm	82	103	123	144	164	185	205	226	246	
			NC (Noise Criteria)	18	23	27	30	33	35	38	40	41	
14x6	0.58	0.48	Airflow, cfm	96	120	144	168	192	216	240	264	288	
			NC (Noise Criteria)	19	24	28	32	34	37	39	41	43	
16x6	0.67	0.57	Airflow, cfm	114	143	171	200	228	257	285	314	342	
			NC (Noise Criteria)	20	24	28	31	34	36	38	40	42	
10x10	0.69	0.59	Airflow, cfm	118	148	177	207	236	266	295	325	354	
			NC (Noise Criteria)	20	25	28	32	34	37	39	41	43	
18x6	0.75	0.63	Airflow, cfm	126	158	189	221	252	284	315	347	378	
			NC (Noise Criteria)	20	25	29	32	35	37	39	41	43	
20x6	0.83	0.72	Airflow, cfm	144	180	216	252	288	324	360	396	432	
			NC (Noise Criteria)	21	25	29	33	35	38	40	42	44	
22x6	0.92	0.77	Airflow, cfm	154	193	231	270	308	347	385	424	462	
			NC (Noise Criteria)	21	26	30	33	36	38	40	42	44	
24x6	1.00	0.88	Airflow, cfm	176	220	264	308	352	396	440	484	528	
			NC (Noise Criteria)	22	26	30	33	36	39	41	43	45	
30x6	1.25	1.11	Airflow, cfm	222	278	333	389	444	500	555	611	666	
			NC (Noise Criteria)	23	27	31	34	37	40	42	44	46	
14x14	1.36	1.22	Airflow, cfm	244	305	366	437	488	549	610	671	732	
			NC (Noise Criteria)	23	28	32	35	38	40	42	44	46	
18x12	1.50	1.35	Airflow, cfm	270	338	405	473	540	608	675	743	810	
			NC (Noise Criteria)	24	28	32	35	38	41	43	45	47	
22x10	1.53	1.37	Airflow, cfm	274	343	411	480	548	617	685	754	822	
			NC (Noise Criteria)	24	28	32	35	38	41	43	45	47	
30x8	1.67	1.49	Airflow, cfm	298	373	447	522	596	671	745	820	894	
			NC (Noise Criteria)	24	28	32	35	38	41	43	45	47	
42x6	1.75	1.59	Airflow, cfm	318	398	477	557	636	716	795	875	954	
			NC (Noise Criteria)	24	29	33	36	39	41	43	45	47	
16x16	1.78	1.62	Airflow, cfm	324	405	486	567	648	729	810	891	972	
			NC (Noise Criteria)	24	29	33	36	39	41	44	46	47	
24x12	2.00	1.82	Airflow, cfm	364	455	546	637	728	819	910	1001	1092	
			NC (Noise Criteria)	25	30	33	37	39	42	44	46	48	
18x18	2.25	2.07	Airflow, cfm	414	518	621	725	828	932	1035	1139	1242	
			NC (Noise Criteria)	25	30	34	37	40	42	45	47	48	
24x14	2.33	2.14	Airflow, cfm	428	535	642	749	856	963	1070	1177	1284	
			NC (Noise Criteria)	26	30	34	37	40	42	45	47	49	
30x12	2.50	2.29	Airflow, cfm	458	573	687	802	916	1031	1145	1260	1374	
			NC (Noise Criteria)	26	31	34	38	40	43	45	47	49	
24x16	2.67	2.46	Airflow, cfm	493	615	738	861	984	1107	1230	1353	1476	
			NC (Noise Criteria)	26	31	35	38	41	43	45	47	49	
20x20	2.78	2.57	Airflow, cfm	514	643	771	900	1028	1157	1285	1414	1542	
			NC (Noise Criteria)	26	31	35	38	41	43	46	48	49	
30x16	3.33	3.11	Airflow, cfm	622	778	933	1089	1244	1400	1555	1711	1866	
			NC (Noise Criteria)	27	32	36	39	42	44	46	48	50	
22x22	3.36	3.14	Airflow, cfm	628	785	942	1099	1256	1413	1570	1727	1884	
			NC (Noise Criteria)	27	32	36	39	42	44	46	48	50	
24x22	3.67	3.43	Airflow, cfm	686	858	1029	1201	1372	1544	1715	1887	2058	
			NC (Noise Criteria)	28	32	36	39	42	45	47	49	51	
30x18	3.75	3.50	Airflow, cfm	700	875	1050	1225	1400	1575	1750	1925	2100	
			NC (Noise Criteria)	28	32	36	39	42	45	47	49	51	
24x24	4.00	3.75	Airflow, cfm	750	938	1125	1313	1500	1688	1875	2063	2250	
			NC (Noise Criteria)	28	33	36	40	43	45	47	49	51	
30x24	5.00	4.71	Airflow, cfm	942	1178	1413	1649	1884	2120	2355	2591	2826	
			NC (Noise Criteria)	29	34	37	41	43	46	48	50	52	
28x28	5.44	5.16	Airflow, cfm	1032	1290	1548	1806	2064	2322	2580	2838	2096	
			NC (Noise Criteria)	29	34	38	41	44	46	49	51	52	
30x28	5.83	5.51	Airflow, cfm	1102	1378	1653	1929	2204	2480	2755	3031	3306	
			NC (Noise Criteria)	30	34	38	41	44	47	49	51	53	
30x30	6.25	5.94	Airflow, cfm	1188	1485	1782	2079	2376	2673	2970	3267	3564	
			NC (Noise Criteria)	30	35	38	42	44	47	49	51	53	

NC 50

• Static pressures are negative, in inches of water, measured per ANSI/ASHRAE Standard 70-2006

• NC based on room absorption of 10dB, re 10⁻¹² watts, measured per ANSI/ASHRAE Standard 70-2006

Reversible Core Grilles

specialized grilles

1700 (L / S)

- Remove, invert or reverse the core for four different vertical deflections
- With its deep, rigid aluminum blades and carefully contoured aluminum border, the Titus 1700 Series offers a look of refinement backed with strength, versatility and superb performance
- Extreme flexibility in adjusting airflow patterns. The fixed blade core can be lifted out, then rotated or reversed, to give four different vertical deflection angles as shown in the illustration below. In addition, the optional Model 07 back blades can be adjusted individually for various horizontal deflection angles.

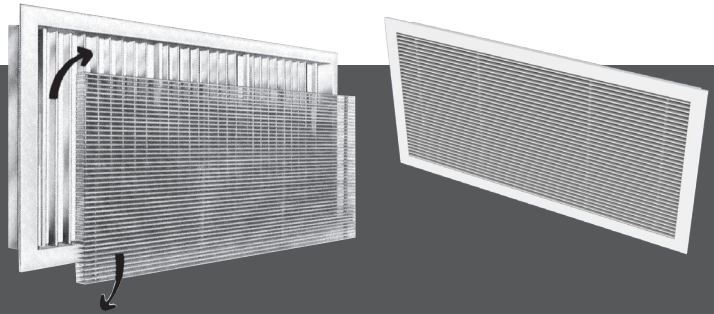

1700 (L / S)

Core is easily removed with one pull on the detachable operating lever, as shown. $\frac{5}{32}$ " mounting holes are concealed inside the border, accessible by removing the core.



metric sizes

AVAILABLE MODELS:

1700L
1700S

FINISH

Standard Finish - #26 White

OVERVIEW

Narrow Blade Grilles

Titus reversible core, narrow blade grilles provide the option of a 15° or 5° blade deflection in the same grille. The core is easily removed using a detachable lever. These grilles are made of extruded aluminum construction. Also available with rear deflection blades.

PRODUCTS INCLUDE

- Available Border Types:
#1 - Surface Mount
#8 - Core Only
- #8 x 11/4" long Phillips Flat Head Sheet Metal Screws, Painted White
- Optional 07 Directional Blades
- Optional Opposed Blade Damper
- Can be used as supply or return



See website for Specifications

Four Different Vertical Deflections Chosen by Positioning Core

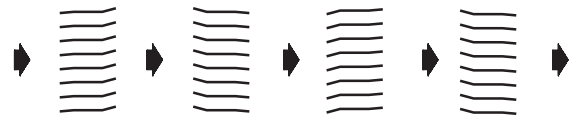

Core Removal and Replacement

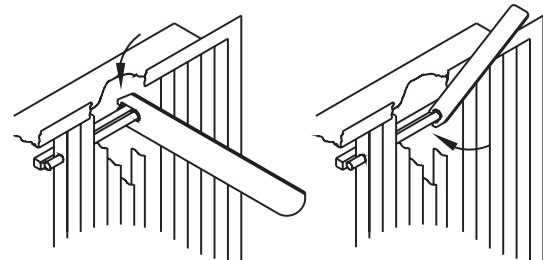

To replace core, insert operating lever through blades, hook over mullion and push downward on lever

1700 (L / S) DIMENSIONS

1700 (L, S) / Border Type 1

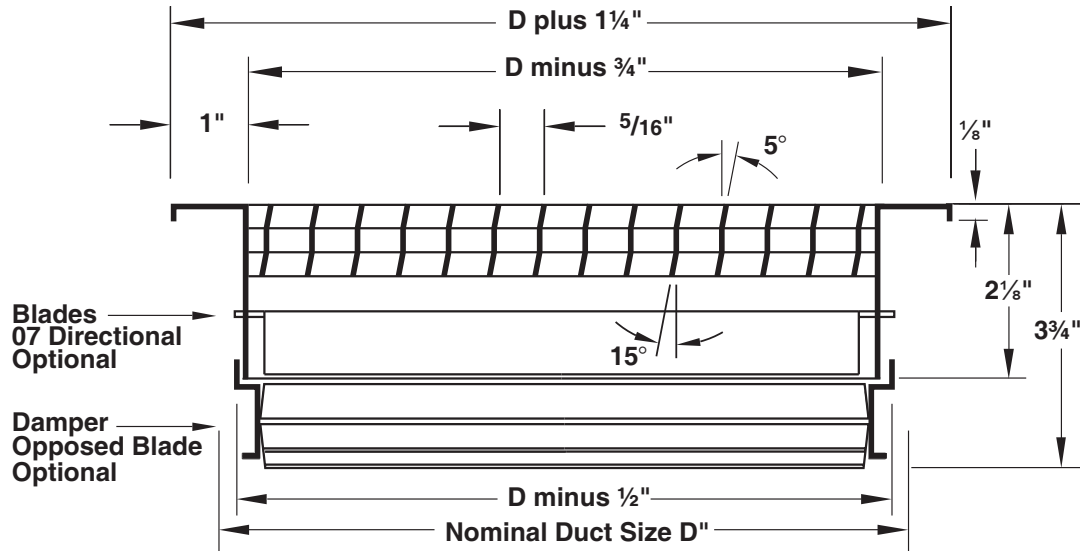

Available sizes (D" x D") Border Type are 6 x 4 inches (1700L) or 6 x 6 inches (1700S) through 72 x 24 inches in single core construction or through 72 x 36 inches in multiple core construction in 1" increments

Border Type 8 (Core Only)

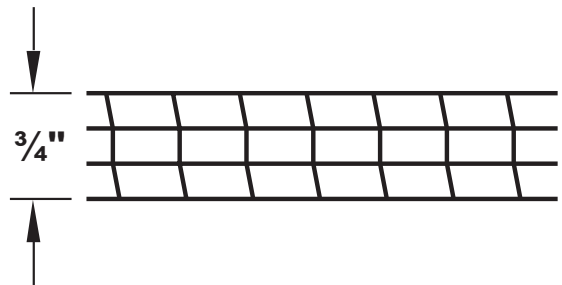

Supplied with Blades = $D \text{ minus } \frac{25}{32}$ "
Tubes = $D \text{ minus } \frac{3}{4}$ "

1700 / SUPPLY

NC 20

NC 30

Core Area, sq. ft.	Nominal Duct Size, inches	Core Vel.		300		400		500		600		700		800		1000		1200		1400	
		Vel. Press.		0.006		0.010		0.016		0.022		0.030		0.040		0.062		0.090		0.122	
		Total Pres.	0°	0.017	0.028	0.045	0.062	0.084	0.112	0.174	0.252	0.341									
0.18	8 X 4 7 X 5 6 X 6		Throw, ft.	22 1/2°	0.019	0.031	0.050	0.068	0.093	0.124	0.192	0.279	0.378								
		45°		0.020	0.034	0.054	0.075	0.102	0.136	0.211	0.306	0.415									
		0°		55	70	90	110	125	145	180	215	250									
0.26	12 X 4 10 X 5 8 X 6	Throw, ft.	22 1/2°	4-7-13	6-8-15	7-12-17	10-14-19	11-15-20	12-16-22	14-17-24	15-19-26	17-21-29									
			45°	3-6-10	5-6-12	6-10-14	7-11-15	8-12-16	10-13-18	11-14-19	12-15-21	14-17-23									
			0°	80	105	130	155	180	210	260	310	365									
0.34	16 X 4 12 X 5 10 X 6	Throw, ft.	22 1/2°	5-8-16	7-12-19	10-14-21	11-17-23	13-17-24	15-19-26	17-21-29	19-23-32	20-25-35									
			45°	4-6-13	6-10-15	7-11-17	8-14-18	11-14-19	12-15-21	14-17-23	15-18-26	16-20-22									
			0°	100	135	170	205	240	270	340	410	475									
0.39	18 X 4 14 X 5 12 X 6 8 X 8	Throw, ft.	22 1/2°	6-10-19	10-14-23	12-17-25	14-20-28	16-22-30	18-23-32	21-26-36	23-27-40	25-30-42									
			45°	5-7-15	7-11-18	10-14-20	11-16-22	13-18-24	15-18-26	17-21-29	18-22-32	20-24-34									
			0°	115	155	195	235	275	310	390	470	545									
0.52	24 X 4 18 X 5 16 X 6	Throw, ft.	22 1/2°	7-12-23	11-16-26	14-20-29	16-23-32	19-25-35	21-26-37	24-30-41	27-33-45	29-35-49									
			45°	6-10-18	8-13-21	11-16-23	13-19-26	15-20-28	17-21-30	19-24-33	22-26-36	23-28-39									
			0°	155	210	260	310	365	415	520	625	730									
0.60	28 X 4 20 X 5 18 X 6 12 X 8 10 X 10	Throw, ft.	22 1/2°	7-13-24	12-17-28	15-21-31	17-25-34	20-27-37	23-29-40	26-32-45	29-35-48	31-38-52									
			45°	6-11-19	10-14-22	12-17-25	14-20-27	16-22-30	19-23-32	21-26-36	23-28-38	25-30-42									
			0°	180	240	300	360	420	480	600	720	840									
0.69	30 X 4 24 X 5 20 X 6 14 X 8 12 X 10	Throw, ft.	22 1/2°	8-14-26	13-18-30	16-23-34	19-27-37	22-29-40	25-31-43	28-34-47	30-38-52	33-40-56									
			45°	6-11-21	11-15-24	13-19-27	15-22-30	18-23-32	20-25-34	22-27-38	24-30-42	26-32-45									
			0°	205	275	345	415	485	550	690	830	965									
0.81	36 X 4 28 X 5 22 X 6 16 X 8 14 X 10	Throw, ft.	22 1/2°	8-15-28	14-20-33	17-24-37	20-29-40	24-31-43	27-33-46	30-37-51	33-41-56	36-44-60									
			45°	6-12-22	11-16-26	14-19-30	16-23-32	19-25-34	22-26-37	24-30-41	26-33-45	29-35-48									
			0°	245	325	405	485	565	650	810	970	1130									
0.90	40 X 4 30 X 5 26 X 6 18 X 8 16 X 10 12 X 12	Throw, ft.	22 1/2°	10-16-30	15-21-34	18-26-39	22-31-42	25-33-45	28-35-48	32-39-55	35-43-59	37-46-63									
			45°	7-13-24	12-17-27	15-21-31	18-25-34	20-26-36	23-28-38	26-31-44	28-34-47	30-37-50									
			0°	270	360	450	540	630	720	900	1080	1260									
1.07	48 X 4 36 X 5 30 X 6 18 X 10 14 X 12	Throw, ft.	22 1/2°	11-17-32	16-23-38	19-30-42	23-35-46	28-36-46	31-38-53	35-43-59	38-46-64	41-50-69									
			45°	8-14-26	13-19-30	15-23-34	19-28-37	22-29-39	24-30-42	28-34-47	30-37-51	33-40-55									
			0°	320	430	535	640	750	855	1070	1280	1500									
1.18	34 X 6 24 X 8 20 X 10 16 X 12 14 X 14	Throw, ft.	22 1/2°	11-18-34	16-24-40	20-30-44	24-37-48	29-38-52	33-40-56	36-45-62	40-48-67	43-52-73									
			45°	8-15-27	13-19-32	16-23-35	19-30-38	23-30-42	27-32-45	29-36-50	32-38-50	34-42-58									
			0°	355	470	590	710	825	945	1180	1420	1650									
1.34	60 X 4 48 X 5 36 X 6 18 X 12 16 X 14	Throw, ft.	22 1/2°	12-19-36	17-25-42	21-32-47	25-39-51	30-40-56	34-43-59	39-47-65	42-52-72	45-56-78									
			45°	10-15-29	14-20-34	17-25-38	20-32-41	23-32-45	28-34-47	31-38-52	34-42-58	36-45-62									
			0°	400	535	670	805	940	1070	1340	1610	1880									
1.60	72 X 4 30 X 8 24 X 10 22 X 12 18 X 14 16 X 16	Throw, ft.	22 1/2°	14-21-40	19-28-46	22-34-51	29-41-56	33-43-60	37-46-64	42-51-72	46-56-79	49-61-85									
			45°	11-17-32	15-22-37	19-28-41	23-33-45	27-34-48	30-37-51	34-41-58	37-45-63	39-49-68									
			0°	480	640	800	960	1120	1280	1600	1920	2240									
1.80	60 X 5 48 X 6 36 X 8 30 X 10 24 X 12 20 X 14 18 X 16	Throw, ft.	22 1/2°	14-22-42	20-30-48	25-37-55	31-45-59	34-46-63	39-49-68	45-55-76	48-60-84	52-65-90									
			45°	11-18-34	16-23-38	20-30-44	24-36-47	28-37-50	32-39-54	36-44-61	38-48-67	42-52-72									
			0°	540	720	900	1080	1260	1440	1800	2160	2520									

NC 40

Performance notes appear at end of table

1700 / SUPPLY

Core Area, sq. ft.	Nominal Duct Size, inches	Core Vel. Vel. Press.	NC 20			NC 30			NC 40			
			300	400	500	600	700	800	1000	1200	1400	
			0.006	0.010	0.016	0.022	0.030	0.040	0.062	0.090	0.122	
2.08	20 X 16 18 X 18 40 X 8 36 X 10 30 X 12 24 X 14	Total Pres.	22 1/2°	0.017 0.019 0.020	0.028 0.031 0.034	0.045 0.050 0.054	0.062 0.068 0.075	0.084 0.093 0.102	0.112 0.124 0.136	0.174 0.192 0.211	0.252 0.279 0.306	0.341 0.378 0.415
		cfm		625	830	1040	1250	1460	1660	2080	2500	2910
		NC		—	—	17	22	27	31	37	43	48
		Throw, ft.	0°	15-24-45	21-32-52	28-40-58	32-47-63	37-49-68	42-53-73	48-59-82	52-64-90	56-69-97
2.45	48 X 8 32 X 12 26 X 14 24 X 16 20 X 18 20 X 20	Total Pres.	22 1/2°	0.017 0.019 0.020	0.028 0.031 0.034	0.045 0.050 0.054	0.062 0.068 0.075	0.084 0.093 0.102	0.112 0.124 0.136	0.174 0.192 0.211	0.252 0.279 0.306	0.341 0.378 0.415
		cfm		735	980	1220	1470	1720	1960	2450	2940	3430
		NC		—	11	18	23	28	32	38	44	49
		Throw, ft.	0°	16-27-49	23-35-57	29-42-62	34-51-68	40-54-74	46-57-80	52-64-89	57-70-97	61-76-106
2.78	36 X 12 30 X 14 26 X 16 24 X 18 22 X 20	Total Pres.	22 1/2°	0.017 0.019 0.020	0.028 0.031 0.034	0.045 0.050 0.054	0.062 0.068 0.075	0.084 0.093 0.102	0.112 0.124 0.136	0.174 0.192 0.211	0.252 0.279 0.306	0.341 0.378 0.415
		cfm		835	1110	1390	1670	1950	2220	2780	3340	3890
		NC		—	11	18	23	28	32	38	44	49
		Throw, ft.	0°	17-28-52	24-36-60	31-45-67	37-53-73	42-57-79	48-57-79	55-68-95	60-75-104	65-81-112
3.11	48 X 10 26 X 18 24 X 20 40 X 12 36 X 14 30 X 16	Total Pres.	22 1/2°	0.017 0.019 0.020	0.028 0.031 0.034	0.045 0.050 0.054	0.062 0.068 0.075	0.084 0.093 0.102	0.112 0.124 0.136	0.174 0.192 0.211	0.252 0.279 0.306	0.341 0.378 0.415
		cfm		935	1240	1560	1870	2180	2490	3110	3730	4350
		NC		—	12	19	24	29	33	39	45	50
		Throw, ft.	0°	18-29-55	25-38-63	36-48-71	43-56-78	50-60-84	51-64-90	58-72-100	64-79-110	69-86-118
3.61	24 X 24 60 X 10 48 X 12 36 X 16 30 X 18	Total Pres.	22 1/2°	0.017 0.019 0.020	0.028 0.031 0.034	0.045 0.050 0.054	0.062 0.068 0.075	0.084 0.093 0.102	0.112 0.124 0.136	0.174 0.192 0.211	0.252 0.279 0.306	0.341 0.378 0.415
		cfm		1080	1440	1800	2170	2530	2890	3610	4330	5050
		NC		—	13	20	25	30	34	40	46	51
		Throw, ft.	0°	19-31-59	28-40-68	34-50-76	40-59-84	47-65-90	54-69-97	63-78-108	69-86-118	75-93-128
4.65	72 X 10 48 X 16 36 X 20 30 X 24	Total Pres.	22 1/2°	0.017 0.019 0.020	0.028 0.031 0.034	0.045 0.050 0.054	0.062 0.068 0.075	0.084 0.093 0.102	0.112 0.124 0.136	0.174 0.192 0.211	0.252 0.279 0.306	0.341 0.378 0.415
		cfm		1400	1860	2320	2790	3260	3720	4650	5580	6510
		NC		—	14	21	26	31	35	41	47	52
		Throw, ft.	0°	21-35-67	31-46-78	38-57-87	47-69-95	54-74-103	61-79-110	72-89-123	79-97-135	86-105-146
5.58	72 X 12 60 X 14 48 X 18 36 X 24	Total Pres.	22 1/2°	0.017 0.019 0.020	0.028 0.031 0.034	0.045 0.050 0.054	0.062 0.068 0.075	0.084 0.093 0.102	0.112 0.124 0.136	0.174 0.192 0.211	0.252 0.279 0.306	0.341 0.378 0.415
		cfm		1670	2230	2790	3350	3910	4460	5580	670	7810
		NC		—	15	22	27	32	36	42	48	53
		Throw, ft.	0°	23-38-73	33-50-85	42-63-95	50-76-104	58-81-113	67-87-122	79-97-135	87-107-148	93-116-160

Redefine your comfort zone.™ | www.titus-hvac.com

NC 50

- When used as a return, add 7 NC to the NC value shown in the supply table. The negative static pressure is 2.4 times the velocity pressure shown.
- Each NC value is based on grille operation at a 0° deflection. If the 07 Blades are adjusted to 22 1/2° or 45, Increase the stated sound levels by 1 or 7 NC respectively.
- See the section, Engineering Guidelines, in this catalog for throw information

JFA (L / S)

JFA-L

- Individually adjustable extruded aluminum front blades, 3/4" centers
- Steel rear blades gang operated
- Pole operator handle for adjusting rear blades
- Blades parallel to the long dimension
- 20-gauge steel frame

JFA-S

- Same as JFA-L with blades parallel to the short dimension

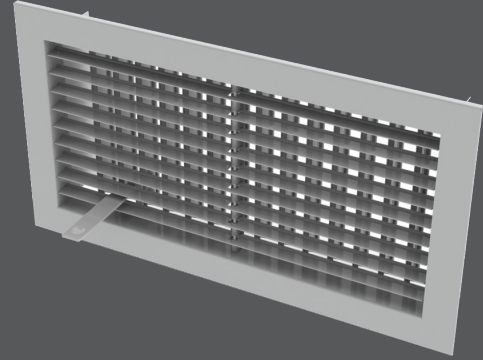

JFA (L / S)



metric sizes



factories

AVAILABLE MODELS:

JFA-L
JFA-S

FINISH

Standard Finish - #26 White

OVERVIEW

Pole Operated Supply Grilles

These supply grilles are great for commercial / industrial applications. The pole operated rear blades are ganged for easy adjustment. Extruded aluminum front blades are individually adjustable for additional versatility.

PRODUCTS INCLUDE

- Available Border Types:
 - #1 - Surface Mount
- #8 x 11/4" long Phillips Flat Head Sheet Metal Screws, Painted White
- Countersunk Screw Holes
- Optional Steel Opposed-Blade Damper



See website for Specifications

JFA (L / S) DIMENSIONS

Pole Operated JFA (L, S) / Border Type 1

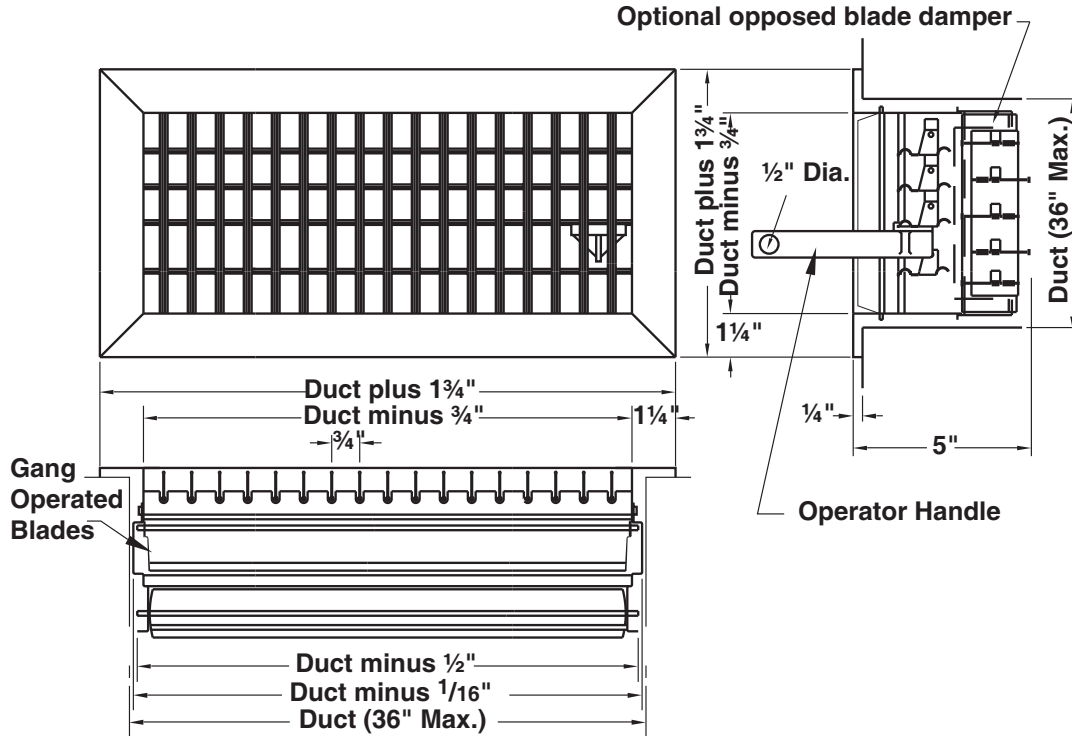

Available sizes (D" x D") Border Type 1 are 10 x 6 inches to 40 x 36 inches in 2" increments

Changes in activity in the conditioned space may require frequent changes in airflow pattern from the supply outlets. Or, the changeover from heating to cooling may call for a shift from a low deflection angle to a high one. In these situations, pole operated supply grilles are time savers. The adjusting lever can be moved with a pole from the floor without a ladder.

JFA / SUPPLY

Redefine your comfort zone™ | www.titus-hvac.com

Core Area, sq. ft.	Nominal Duct Size, inches	Core Vel.	NC 20						NC 30		NC 40	
			300	400	500	600	700	800	1000	1200	1400	
		Vel. Press.	0.006	0.010	0.016	0.022	0.030	0.040	0.062	0.090	0.122	
		Total Pres.	0°	0.010	0.017	0.028	0.038	0.052	0.069	0.107	0.156	0.211
			22 1/2°	0.011	0.019	0.031	0.043	0.058	0.078	0.120	0.175	0.237
			45°	0.016	0.029	0.047	0.064	0.088	0.117	0.181	0.263	0.356
0.15	7 X 4 6 X 5	cfm	45	60	75	90	105	120	150	180	210	
		NC	—	—	—	—	13	17	23	29	34	
		Throw, ft.	0°	4-6-12	5-8-14	7-10-16	8-12-17	9-13-19	11-14-20	13-16-22	14-17-24	15-19-26
			22 1/2°	3-5-10	4-6-11	6-8-13	6-10-14	7-10-15	9-11-16	10-13-18	11-14-19	12-15-21
0.18	8 X 4 7 X 5 6 X 6	cfm	55	70	90	110	125	145	180	215	250	
		NC	—	—	—	10	15	19	25	31	36	
		Throw, ft.	0°	4-7-13	6-8-15	7-11-17	9-13-19	10-15-20	11-16-22	14-17-24	15-19-26	17-21-29
			22 1/2°	3-6-10	5-6-12	6-9-14	7-10-15	8-12-16	9-13-18	11-14-19	12-15-21	14-17-23
0.22	10 X 4 8 X 5 7 X 6	cfm	65	90	110	130	155	175	220	265	310	
		NC	—	—	—	10	15	19	25	31	36	
		Throw, ft.	0°	4-7-14	7-10-17	8-12-19	9-15-21	11-16-23	13-17-24	16-19-27	17-21-29	19-23-32
			22 1/2°	3-6-11	6-8-14	6-10-15	7-12-17	9-13-18	10-14-19	13-15-22	14-17-23	15-18-26
0.26	12 X 4 10 X 5 8 X 6	cfm	80	105	130	155	180	210	260	310	365	
		NC	—	—	—	11	16	20	26	32	37	
		Throw, ft.	0°	5-8-16	7-11-19	9-13-21	10-16-23	12-17-24	14-19-26	17-21-29	19-23-32	20-25-35
			22 1/2°	4-6-13	6-9-15	7-10-17	8-13-18	10-14-19	11-15-21	14-17-23	15-18-26	16-20-28
0.34	16 X 4 12 X 5 10 X 6	cfm	100	135	170	205	240	270	340	410	475	
		NC	—	—	—	12	17	21	27	33	38	
		Throw, ft.	0°	5-9-18	8-12-21	10-15-24	12-19-26	14-20-28	16-22-30	20-24-33	22-26-37	23-28-40
			22 1/2°	4-7-14	6-10-17	8-12-19	10-15-21	11-16-22	13-18-24	16-19-26	18-21-30	18-22-32
0.39	18 X 4 14 X 5 12 X 6 8 X 8	cfm	115	155	195	235	275	310	390	470	545	
		NC	—	—	—	13	18	22	28	34	39	
		Throw, ft.	0°	6-9-19	9-13-23	11-16-25	13-19-28	15-22-30	17-23-32	21-26-36	23-27-40	25-30-42
			22 1/2°	5-7-15	7-10-18	9-13-20	10-15-22	12-18-24	14-18-26	17-21-29	18-22-32	20-24-34
0.46	20 X 4 16 X 5 14 X 6 10 X 8	cfm	140	185	230	275	320	370	460	550	645	
		NC	—	—	—	13	18	22	28	34	39	
		Throw, ft.	0°	7-10-22	9-14-25	12-17-27	14-22-30	16-23-32	19-25-35	23-27-39	25-31-43	27-33-46
			22 1/2°	6-8-18	7-11-20	10-14-22	11-18-24	13-18-26	15-20-28	18-22-31	20-25-34	22-26-37
0.60	28 x 4 20 x 5 18 x 6 12 x 8 10 x 10	cfm	180	240	300	360	420	480	600	720	840	
		NC	—	—	10	15	20	24	30	36	41	
		Throw, ft.	0°	7-12-24	11-16-28	14-20-31	16-24-34	19-27-37	22-29-40	26-32-45	29-35-48	31-38-52
			22 1/2°	6-10-19	9-13-22	11-16-25	13-19-27	15-22-30	18-23-32	21-26-36	23-28-38	25-30-42
0.69	30 x 4 24 x 5 20 x 6 14 x 8 12 x 10	cfm	205	275	345	415	485	550	690	830	965	
		NC	—	—	10	15	20	24	30	36	41	
		Throw, ft.	0°	8-13-26	12-17-30	15-22-34	18-26-37	21-29-40	24-31-43	28-34-47	30-38-52	33-40-56
			22 1/2°	6-10-21	10-14-24	12-18-27	14-21-30	17-23-32	19-25-34	22-27-38	24-30-42	26-32-45
		45°	4-6-13	6-9-15	7-11-17	9-13-18	10-14-20	12-15-21	14-17-24	15-19-26	16-20-28	

PERFORMANCE DATA

JFA / SUPPLY

Core Area, sq. ft.	Nominal Duct Size, inches	Core Vel. Vel. Press.	NC 20				NC 30		NC 40			
			300	400	500	600	700	800	1000	1200	1400	
			0	0.010	0.017	0.028	0.038	0.052	0.069	0.107	0.156	0.211
0.81	36x4 28x5 22x6 16x8 14x10	Total Pres.	22 ½	0.011	0.019	0.031	0.043	0.058	0.078	0.120	0.175	0.237
			45	0.016	0.029	0.047	0.064	0.088	0.117	0.181	0.263	0.356
		Throw, ft.	0°	8-14-28	13-19-33	16-23-37	19-28-40	23-31-43	26-33-46	30-37-51	33-41-56	36-44-60
			22½°	6-11-22	10-15-26	13-18-30	15-22-32	18-25-34	21-26-37	24-30-41	26-33-45	29-35-48
0.90	40x4 30x5 26x6 18x8 16x10 12x12	Total Pres.	22 ½	0.011	0.019	0.031	0.043	0.058	0.078	0.120	0.175	0.237
			45	0.016	0.029	0.047	0.064	0.088	0.117	0.181	0.263	0.356
		Throw, ft.	0°	9-15-30	14-20-34	17-25-39	21-30-42	24-33-45	27-35-48	32-39-55	35-43-59	37-46-63
			22½°	7-12-24	11-16-27	14-20-31	17-24-34	19-26-36	2-28-38	26-31-44	28-34-47	30-37-50
1.07	48x4 36x5 30x6 18x10 14x12	Total Pres.	22 ½	0.011	0.019	0.031	0.043	0.058	0.078	0.120	0.175	0.237
			45	0.016	0.029	0.047	0.064	0.088	0.117	0.181	0.263	0.356
		Throw, ft.	0°	10-16-32	15-22-38	18-28-42	22-33-46	26-36-49	29-38-53	35-43-59	38-46-64	41-50-69
			22½°	8-13-26	12-18-30	14-22-34	18-26-37	21-29-39	23-30-42	28-34-47	30-37-51	33-40-55
1.18	34x6 24x8 20x10 16x12 14x14	Total Pres.	22 ½	0.011	0.019	0.031	0.043	0.058	0.078	0.120	0.175	0.237
			45	0.016	0.029	0.047	0.064	0.088	0.117	0.181	0.263	0.356
		Throw, ft.	0°	10-17-34	15-23-40	19-28-44	23-35-48	27-38-52	31-40-56	36-45-62	40-48-67	43-52-73
			22½°	8-14-27	12-18-32	15-22-35	18-28-38	22-30-42	25-32-45	29-36-50	32-38-54	34-42-58
1.34	60x4 48x5 36x6 18x12 16x14	Total Pres.	22 ½	0.011	0.019	0.031	0.043	0.058	0.078	0.120	0.175	0.237
			45	0.016	0.029	0.047	0.064	0.088	0.117	0.181	0.263	0.356
		Throw, ft.	0°	11-18-36	16-24-42	20-30-47	24-37-51	28-40-56	32-43-59	39-47-65	42-52-72	45-56-78
			22½°	9-14-29	13-19-34	16-24-38	19-30-41	22-32-45	26-34-47	31-38-52	34-42-58	36-45-62
1.60	72x4 30x8 24x10 22x12 18x14 16x16	Total Pres.	22 ½	0.011	0.019	0.031	0.043	0.058	0.078	0.120	0.175	0.237
			45	0.016	0.029	0.047	0.064	0.088	0.117	0.181	0.263	0.356
		Throw, ft.	0°	13-20-40	18-26-46	22-32-51	27-39-56	31-43-60	35-46-64	42-51-72	46-56-79	49-63-85
			22½°	10-16-32	14-21-37	18-26-41	22-31-45	25-34-48	28-37-51	34-41-58	37-45-63	39-49-68
1.80	60x5 48x6 36x8 30x10 24x12 20x14 18x16	Total Pres.	22 ½	0.011	0.019	0.031	0.043	0.058	0.078	0.120	0.175	0.237
			45	0.016	0.029	0.047	0.064	0.088	0.117	0.181	0.263	0.356
		Throw, ft.	0°	13-21-42	19-28-48	24-35-55	29-43-59	32-46-63	37-49-68	45-55-76	48-60-84	52-65-90
			22½°	10-17-34	15-22-38	19-28-44	23-34-47	26-37-50	30-39-54	36-44-61	38-48-67	42-52-72
2.08	60x6 40x8 36x10 30x12 24x14 20x16 18x18	Total Pres.	22 ½	0.011	0.019	0.031	0.043	0.058	0.078	0.120	0.175	0.237
			45	0.016	0.029	0.047	0.064	0.088	0.117	0.181	0.263	0.356
		Throw, ft.	0°	14-23-45	20-30-52	26-38-58	30-44-63	35-49-68	40-53-73	48-59-82	52-64-90	56-69-97
			22½°	11-18-36	16-24-42	21-30-46	24-35-50	28-39-54	32-42-58	38-47-66	42-51-72	45-55-78
2.45	72x6 48x8 32x12 26x14 24x16 20x18 20x20	Total Pres.	22 ½	0.011	0.019	0.031	0.043	0.058	0.078	0.120	0.175	0.237
			45	0.016	0.029	0.047	0.064	0.088	0.117	0.181	0.263	0.356
		Throw, ft.	0°	15-25-49	22-33-57	27-40-62	32-48-68	38-54-74	43-57-80	52-64-89	57-70-97	61-76-106
			22½°	12-20-39	18-26-46	22-32-50	26-38-54	30-43-59	34-46-64	42-51-71	46-56-78	49-61-85

JFA / SUPPLY

Core Area, sq. ft.	Nom. Duct Size, in.	Core Vel. Vel. Press.	NC 20			NC 30			NC 40	NC 50	
			300	400	500	600	700	800	1000	1200	1400
			0°	0.010	0.017	0.028	0.038	0.052	0.069	0.107	0.156
2.78	36x12	cfm	835	1110	1390	1670	1950	2220	2780	3340	3890
		NC	—	—	16	21	26	30	36	42	47
	Throw, ft.	0°	16-26-52	23-34-60	29-42-67	35-50-73	40-57-79	45-61-85	55-68-95	60-75-104	65-81-112
		22½°	13-21-42	18-27-48	23-34-54	28-40-58	32-46-63	36-49-68	44-54-76	48-60-83	52-65-90
		45°	8-13-26	12-17-30	14-21-33	17-25-37	20-28-40	23-30-42	28-34-47	30-37-52	33-40-56
3.61	72x8	cfm	1080	1440	1800	2170	2530	2890	3610	4330	5050
		NC	—	10	17	22	27	31	37	43	48
	Throw, ft.	0°	18-29-59	26-38-68	32-47-76	38-56-84	44-65-90	51-69-97	63-78-108	69-86-118	75-93-128
		22½°	14-23-47	21-30-54	26-38-61	30-45-67	35-52-72	41-55-78	50-62-86	55-69-94	60-74-102
		45°	9-14-29	13-19-34	16-23-38	19-28-42	22-32-45	25-35-48	31-39-54	35-43-59	38-46-64
4.29	48x14	cfm	1290	1720	2140	2570	3000	3430	4290	5150	6010
		NC	—	11	18	23	28	32	38	44	49
	Throw, ft.	0°	19-31-64	28-41-74	35-50-83	42-60-91	49-71-98	56-76-106	69-85-118	76-93-130	82-102-140
		22½°	15-25-51	22-33-59	28-40-66	34-48-73	39-57-78	45-61-85	55-68-94	61-74-104	66-82-112
		45°	10-15-32	14-20-37	17-25-42	21-30-46	24-35-49	28-38-53	34-43-59	38-47-65	41-51-70
4.65	48x16	cfm	1400	1860	2320	2790	3260	3720	4650	5580	6510
		NC	—	11	18	23	28	32	38	44	49
	Throw, ft.	0°	20-33-67	29-43-78	36-54-87	44-65-95	51-74-103	58-79-110	72-89-123	79-97-135	86-105-146
		22½°	16-26-54	23-34-62	29-43-70	32-52-76	41-59-82	49-63-88	58-71-98	63-78-108	69-84-117
		45°	10-16-33	15-22-39	18-27-43	22-32-48	25-37-52	29-40-55	36-44-61	39-49-67	43-52-73
5.58	36x24	cfm	1670	2230	2790	3350	3910	4460	5580	6700	7810
		NC	—	12	19	24	29	33	39	45	50
	Throw, ft.	0°	22-36-73	31-47-85	40-59-95	47-72-104	55-81-113	63-87-122	79-97-135	87-107-148	93-116-160
		22½°	18-29-58	25-38-68	32-47-76	38-58-83	44-65-90	50-70-98	63-78-108	70-86-118	74-93-130
		45°	11-18-37	16-23-43	20-30-48	23-36-52	28-41-57	31-44-61	39-49-67	43-53-74	47-53-80
6.25	30x30	cfm	1880	2500	3120	3750	4380	5000	6250	7500	8750
		NC	—	13	20	25	30	34	40	46	51
	Throw, ft.	0°	23-37-78	33-49-90	42-62-100	50-75-103	58-86-119	67-93-128	84-104-143	92-113-156	98-123-169
		22½°	18-30-62	26-39-72	34-50-80	40-60-82	46-69-95	54-74-102	67-83-114	74-90-125	78-98-135
		45°	12-19-39	17-25-45	21-31-50	25-37-51	29-43-60	34-46-64	42-52-72	46-57-78	49-61-85

PERFORMANCE NOTES

- Data obtained from tests conducted in accordance with ANSI/ASHRAE Standard 70-2006
- All pressures are in inches of water
- Core velocities are in feet per minute
- Throw values are given for isothermal terminal velocities of 150, 100 and 50 fpm. See the section, Engineering Guidelines, in this catalog for throw information.
- Dividing lines denote ranges of NC values
- The stated deflection settings refer to the blade position. For a 20° upward deflection, use the throw rating for the 0° setting and the total pressure for the 22½° horizontal setting.
- Each NC value represents the noise criterion curve that will not be exceeded by the sound pressure in any of the octave bands, 2 through 7. Each NC value is based on a room absorption of 10 dB, re 10⁻¹² watts. Each NC value is further based on a single grille operating at a 0° deflection setting. For deflection settings of 22½° or 45°, increase the stated sound levels by 1 and 7 NC, respectively.
- Dash (—) in space indicates NC value less than 10

VARIABLE AIR VOLUME APPLICATIONS

- All Titus supply grilles can be applied to variable air volume systems with excellent results. For detailed selection methods, consult your Titus representative, or the Engineering Guidelines section of this catalog.

DL

- Length of throw, plus horizontal and vertical direction, can be adjusted by means of the rotating drum and pivoted blades
- Felt seal between the drum and border stops leakage and holds the drum securely in the position selected
- Optional opposed-blade damper with a screwdriver operator accessible through the discharge opening of the drum louver
- Material is aluminum frame with aluminum drum

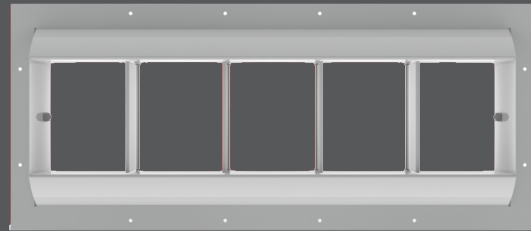

DL



duct mounted

factories

gymnasiums

open areas

airport terminals

AVAILABLE MODEL:

DL

FINISH

Standard Finish - #26 White

OVERVIEW

High Capacity / Long Throw

Titus Model DL drum louvers are especially useful where long throws are required. This requirement occurs in installations where the conditioned space is large, making it impractical to bring the ductwork close to the occupants. Examples of such installations are shopping malls, coliseums, field houses, air terminals, factories and warehouses.

PRODUCTS INCLUDE

- Available Border Types:
#1 - Surface Mount

 See website for Specifications



Drum louver shown in an open ceiling gym environment

DIMENSIONS

DL DIMENSIONS

Drum Louver

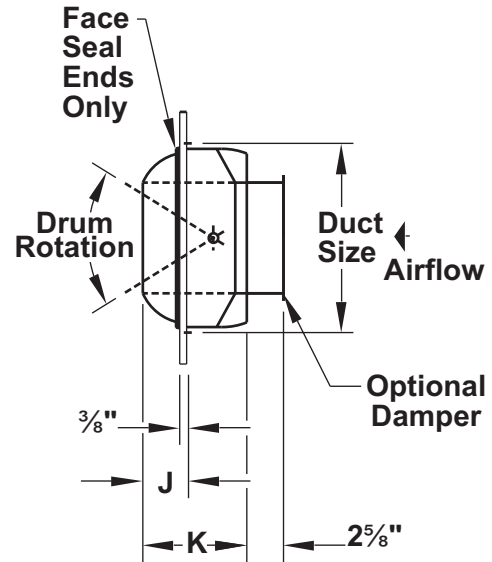
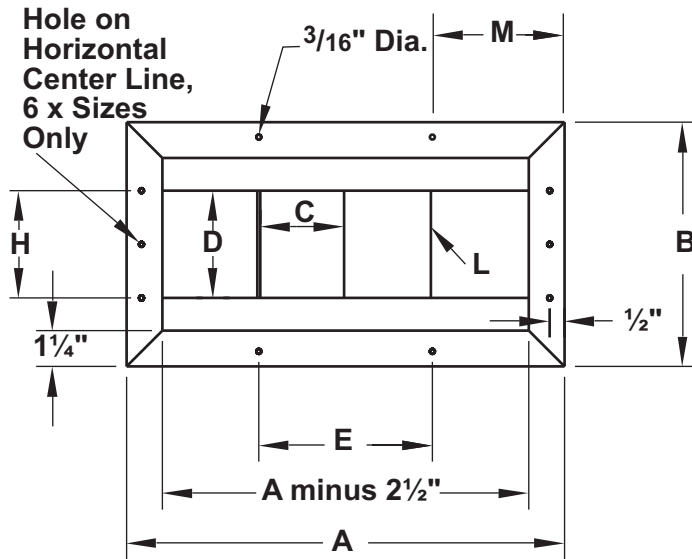

Duct Size	Maximum Rotation (degrees) Above and Below Horizontal Center Line	
	With Damper	Without Damper
6	28°	30°
10	30°	30°
12	25°	25°
15	27°	27°

Listed Size Inches	Duct Size Inches	A	B	C	D	E	H	J	K	L Number or Vanes	M	Number of Screw Holes
9 x 6	9 ⁵ / ₈ x 6 ⁷ / ₁₆	11 ¹¹ / ₁₆	8 ³ / ₁₆	3	3 ³ / ₈	6	—	1 ²¹ / ₃₂	3 ⁵ / ₈	2	2 ²⁷ / ₃₂	8
12 x 6	12 ⁵ / ₈ x 6 ⁷ / ₁₆	14 ¹¹ / ₁₆	8 ³ / ₁₆	3	3 ³ / ₈	6	—	1 ²¹ / ₃₂	3 ⁵ / ₈	3	4 ¹¹ / ₃₂	8
18 x 6	18 ⁵ / ₈ x 6 ⁷ / ₁₆	20 ¹¹ / ₁₆	8 ³ / ₁₆	3	3 ³ / ₈	6	—	1 ²¹ / ₃₂	3 ⁵ / ₈	5	4 ¹¹ / ₃₂	8
24 x 6	24 ⁵ / ₈ x 6 ⁷ / ₁₆	26 ¹¹ / ₁₆	8 ³ / ₁₆	3	3 ³ / ₈	6	—	1 ²¹ / ₃₂	3 ⁵ / ₈	7	4 ¹¹ / ₃₂	10
30 x 6	30 ⁵ / ₈ x 6 ⁷ / ₁₆	32 ¹¹ / ₁₆	8 ³ / ₁₆	3	3 ³ / ₈	6	—	1 ²¹ / ₃₂	3 ⁵ / ₈	9	4 ¹¹ / ₃₂	12
36 x 6	36 ⁵ / ₈ x 6 ⁷ / ₁₆	38 ¹¹ / ₁₆	8 ³ / ₁₆	3	3 ³ / ₈	6	—	1 ²¹ / ₃₂	3 ⁵ / ₈	11	4 ¹¹ / ₃₂	14
48 x 6	48 ⁵ / ₈ x 6 ⁷ / ₁₆	50 ¹¹ / ₁₆	8 ³ / ₁₆	3	3 ³ / ₈	6	—	1 ²¹ / ₃₂	3 ⁵ / ₈	15	4 ¹¹ / ₃₂	18
60 x 6	60 ⁵ / ₈ x 6 ⁷ / ₁₆	62 ¹¹ / ₁₆	8 ³ / ₁₆	3	3 ³ / ₈	6	—	1 ²¹ / ₃₂	3 ⁵ / ₈	19	4 ¹¹ / ₃₂	22
20 x 10	20 ⁵ / ₈ x 10 ³ / ₁₆	22 ¹¹ / ₁₆	11 ¹⁵ / ₁₆	5	5 ³ / ₈	5	6	2 ¹⁷ / ₁₆	6	3	6 ¹¹ / ₃₂	10
25 x 10	25 ⁵ / ₈ x 10 ³ / ₁₆	27 ¹¹ / ₁₆	11 ¹⁵ / ₁₆	5	5 ³ / ₈	5	6	2 ¹⁷ / ₁₆	6	4	6 ¹¹ / ₃₂	12
30 x 10	30 ⁵ / ₈ x 10 ³ / ₁₆	32 ¹¹ / ₁₆	11 ¹⁵ / ₁₆	5	5 ³ / ₈	5	6	2 ¹⁷ / ₁₆	6	5	6 ¹¹ / ₃₂	14
35 x 10	35 ⁵ / ₈ x 10 ³ / ₁₆	37 ¹¹ / ₁₆	11 ¹⁵ / ₁₆	5	5 ³ / ₈	5	6	2 ¹⁷ / ₁₆	6	6	6 ¹¹ / ₃₂	16
40 x 10	40 ⁵ / ₈ x 10 ³ / ₁₆	42 ¹¹ / ₁₆	11 ¹⁵ / ₁₆	5	5 ³ / ₈	5	6	2 ¹⁷ / ₁₆	6	7	6 ¹¹ / ₃₂	18
50 x 10	50 ⁵ / ₈ x 10 ³ / ₁₆	52 ¹¹ / ₁₆	11 ¹⁵ / ₁₆	5	5 ³ / ₈	5	6	2 ¹⁷ / ₁₆	6	9	6 ¹¹ / ₃₂	22
60 x 10	60 ⁵ / ₈ x 10 ³ / ₁₆	62 ¹¹ / ₁₆	11 ¹⁵ / ₁₆	5	5 ³ / ₈	5	6	2 ¹⁷ / ₁₆	6	11	6 ¹¹ / ₃₂	26
70 x 10	70 ⁵ / ₈ x 10 ³ / ₁₆	72 ¹¹ / ₁₆	11 ¹⁵ / ₁₆	5	5 ³ / ₈	5	6	2 ¹⁷ / ₁₆	6	13	6 ¹¹ / ₃₂	30
20 x 12	20 ⁵ / ₈ x 12 ³ / ₁₆	22 ¹¹ / ₁₆	13 ¹⁵ / ₁₆	5	6 ³ / ₈	5	6	3	6	3	6 ¹¹ / ₃₂	9
30 x 12	30 ⁵ / ₈ x 12 ³ / ₁₆	32 ¹¹ / ₁₆	13 ¹⁵ / ₁₆	5	6 ³ / ₈	5	6	3	6	5	6 ¹¹ / ₃₂	14
40 x 12	40 ⁵ / ₈ x 12 ³ / ₁₆	42 ¹¹ / ₁₆	13 ¹⁵ / ₁₆	5	6 ³ / ₈	5	6	3	6	7	6 ¹¹ / ₃₂	18
50 x 12	50 ⁵ / ₈ x 12 ³ / ₁₆	52 ¹¹ / ₁₆	13 ¹⁵ / ₁₆	5	6 ³ / ₈	5	6	3	6	9	6 ¹¹ / ₃₂	22
60 x 12	60 ⁵ / ₈ x 12 ³ / ₁₆	62 ¹¹ / ₁₆	13 ¹⁵ / ₁₆	5	6 ³ / ₈	5	6	3	6	11	6 ¹¹ / ₃₂	26
70 x 12	70 ⁵ / ₈ x 12 ³ / ₁₆	72 ¹¹ / ₁₆	13 ¹⁵ / ₁₆	5	6 ³ / ₈	5	6	3	6	13	6 ¹¹ / ₃₂	30
15 x 15	15 ⁵ / ₈ x 15 ³ / ₁₆	17 ¹¹ / ₁₆	17	5	9 ¹³ / ₁₆	5	9	3 ¹³ / ₁₆	8 ¹ / ₈	2	6 ¹¹ / ₃₂	8
20 x 15	20 ⁵ / ₈ x 15 ³ / ₁₆	22 ¹¹ / ₁₆	17	5	9 ¹³ / ₁₆	5	9	3 ¹³ / ₁₆	8 ¹ / ₈	3	6 ¹¹ / ₃₂	10
25 x 15	25 ⁵ / ₈ x 15 ³ / ₁₆	27 ¹¹ / ₁₆	17	5	9 ¹³ / ₁₆	5	9	3 ¹³ / ₁₆	8 ¹ / ₈	4	6 ¹¹ / ₃₂	12
30 x 15	30 ⁵ / ₈ x 15 ³ / ₁₆	32 ¹¹ / ₁₆	17	5	9 ¹³ / ₁₆	5	9	3 ¹³ / ₁₆	8 ¹ / ₈	5	6 ¹¹ / ₃₂	14
40 x 15	40 ⁵ / ₈ x 15 ³ / ₁₆	42 ¹¹ / ₁₆	17	5	9 ¹³ / ₁₆	5	9	3 ¹³ / ₁₆	8 ¹ / ₈	7	6 ¹¹ / ₃₂	18
50 x 15	50 ⁵ / ₈ x 15 ³ / ₁₆	52 ¹¹ / ₁₆	17	5	9 ¹³ / ₁₆	5	9	3 ¹³ / ₁₆	8 ¹ / ₈	9	6 ¹¹ / ₃₂	22
60 x 15	60 ⁵ / ₈ x 15 ³ / ₁₆	62 ¹¹ / ₁₆	17	5	9 ¹³ / ₁₆	5	9	3 ¹³ / ₁₆	8 ¹ / ₈	11	6 ¹¹ / ₃₂	26
70 x 15	70 ⁵ / ₈ x 15 ³ / ₁₆	72 ¹¹ / ₁₆	17	5	9 ¹³ / ₁₆	5	9	3 ¹³ / ₁₆	8 ¹ / ₈	13	6 ¹¹ / ₃₂	30

Note: Model DL drum louver can be operated at high discharge velocities. However, if at these velocities the static pressure across the drum louver itself is more than 0.25" wg, the optional opposed-blade damper becomes ineffective and is therefore not recommended.

DL-SV

- Length of throw, plus horizontal and vertical direction, can be adjusted by means of the rotating drum and pivoted blades
- Felt seal between the drum and border stops leakage and holds the drum securely in the position selected
- Optional opposed-blade damper with a screwdriver operator accessible through the discharge opening of the drum louver
- Material is aluminum frame with aluminum drum

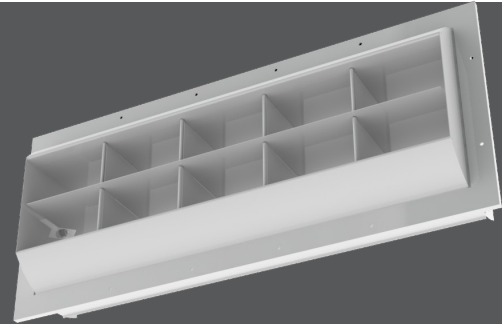

DL-SV



duct mounted



factories



gymnasiums



open areas



airport terminals



See website for Specifications

AVAILABLE MODEL:

DL-SV / Split Vane

FINISH

Standard Finish - #26 White

OVERVIEW

High Capacity / Long Throw

Titus Model DL-SV drum louvers are especially useful where long throws are required. This requirement occurs in installations where the conditioned space is large, making it impractical to bring the ductwork close to the occupants. Examples of such installations are shopping malls, coliseums, field houses, air terminals, factories and warehouses.

PRODUCTS INCLUDE

- Available Border Types:
#1 - Surface Mount
- DL-SV drum grilles employ a split vane design to produce diverging air streams

DIMENSIONS

DL-SV DIMENSIONS

Drum Louver with Split Vane Option

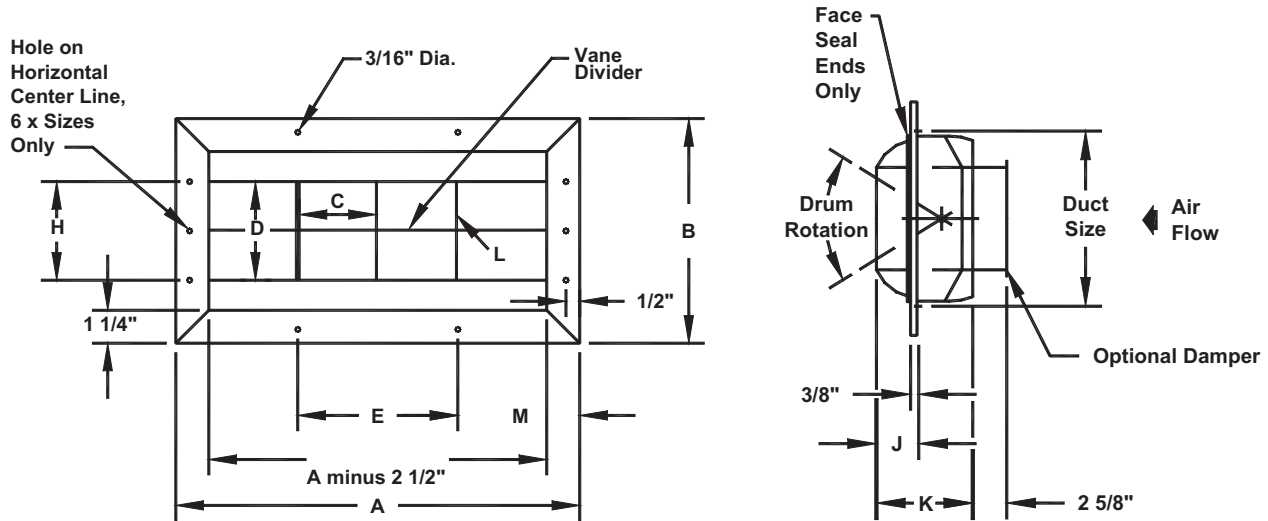

Duct Size	Maximum Rotation (degrees) Above and Below Horizontal Center Line	
	With Damper	Without Damper
6	28°	30°
10	30°	30°
12	25°	25°
15	27°	27°

Listed Size Inches	Duct Size Inches	A	B	C	D	E	H	J	K	L Number of Vanes	M	Number of Screw Holes
9 x 6	9 ⁵ / ₈ x 6 ⁷ / ₁₆	11 ¹¹ / ₁₆	8 ³ / ₁₆	3	3 ³ / ₈	6	—	1 ²¹ / ₃₂	3 ⁵ / ₈	2	2 ²⁷ / ₃₂	8
12 x 6	12 ⁵ / ₈ x 6 ⁷ / ₁₆	14 ¹¹ / ₁₆	8 ³ / ₁₆	3	3 ³ / ₈	6	—	1 ²¹ / ₃₂	3 ⁵ / ₈	3	4 ¹¹ / ₃₂	8
18 x 6	18 ⁵ / ₈ x 6 ⁷ / ₁₆	20 ¹¹ / ₁₆	8 ³ / ₁₆	3	3 ³ / ₈	6	—	1 ²¹ / ₃₂	3 ⁵ / ₈	5	4 ¹¹ / ₃₂	8
24 x 6	24 ⁵ / ₈ x 6 ⁷ / ₁₆	26 ¹¹ / ₁₆	8 ³ / ₁₆	3	3 ³ / ₈	6	—	1 ²¹ / ₃₂	3 ⁵ / ₈	7	4 ¹¹ / ₃₂	10
30 x 6	30 ⁵ / ₈ x 6 ⁷ / ₁₆	32 ¹¹ / ₁₆	8 ³ / ₁₆	3	3 ³ / ₈	6	—	1 ²¹ / ₃₂	3 ⁵ / ₈	9	4 ¹¹ / ₃₂	12
36 x 6	36 ⁵ / ₈ x 6 ⁷ / ₁₆	38 ¹¹ / ₁₆	8 ³ / ₁₆	3	3 ³ / ₈	6	—	1 ²¹ / ₃₂	3 ⁵ / ₈	11	4 ¹¹ / ₃₂	14
48 x 6	48 ⁵ / ₈ x 6 ⁷ / ₁₆	50 ¹¹ / ₁₆	8 ³ / ₁₆	3	3 ³ / ₈	6	—	1 ²¹ / ₃₂	3 ⁵ / ₈	15	4 ¹¹ / ₃₂	18
60 x 6	60 ⁵ / ₈ x 6 ⁷ / ₁₆	62 ¹¹ / ₁₆	8 ³ / ₁₆	3	3 ³ / ₈	6	—	1 ²¹ / ₃₂	3 ⁵ / ₈	19	4 ¹¹ / ₃₂	22
20 x 10	20 ⁵ / ₈ x 10 ³ / ₁₆	22 ¹¹ / ₁₆	11 ¹⁵ / ₁₆	5	5 ³ / ₈	5	6	2 ¹⁷ / ₁₆	6	3	6 ¹¹ / ₃₂	10
25 x 10	25 ⁵ / ₈ x 10 ³ / ₁₆	27 ¹¹ / ₁₆	11 ¹⁵ / ₁₆	5	5 ³ / ₈	5	6	2 ¹⁷ / ₁₆	6	4	6 ¹¹ / ₃₂	12
30 x 10	30 ⁵ / ₈ x 10 ³ / ₁₆	32 ¹¹ / ₁₆	11 ¹⁵ / ₁₆	5	5 ³ / ₈	5	6	2 ¹⁷ / ₁₆	6	5	6 ¹¹ / ₃₂	14
35 x 10	35 ⁵ / ₈ x 10 ³ / ₁₆	37 ¹¹ / ₁₆	11 ¹⁵ / ₁₆	5	5 ³ / ₈	5	6	2 ¹⁷ / ₁₆	6	6	6 ¹¹ / ₃₂	16
40 x 10	40 ⁵ / ₈ x 10 ³ / ₁₆	42 ¹¹ / ₁₆	11 ¹⁵ / ₁₆	5	5 ³ / ₈	5	6	2 ¹⁷ / ₁₆	6	7	6 ¹¹ / ₃₂	18
50 x 10	50 ⁵ / ₈ x 10 ³ / ₁₆	52 ¹¹ / ₁₆	11 ¹⁵ / ₁₆	5	5 ³ / ₈	5	6	2 ¹⁷ / ₁₆	6	9	6 ¹¹ / ₃₂	22
60 x 10	60 ⁵ / ₈ x 10 ³ / ₁₆	62 ¹¹ / ₁₆	11 ¹⁵ / ₁₆	5	5 ³ / ₈	5	6	2 ¹⁷ / ₁₆	6	11	6 ¹¹ / ₃₂	26
70 x 10	70 ⁵ / ₈ x 10 ³ / ₁₆	72 ¹¹ / ₁₆	11 ¹⁵ / ₁₆	5	5 ³ / ₈	5	6	2 ¹⁷ / ₁₆	6	13	6 ¹¹ / ₃₂	30
20 x 12	20 ⁵ / ₈ x 12 ³ / ₁₆	22 ¹¹ / ₁₆	13 ¹⁵ / ₁₆	5	6 ³ / ₈	5	6	3	6	3	6 ¹¹ / ₃₂	9
30 x 12	30 ⁵ / ₈ x 12 ³ / ₁₆	32 ¹¹ / ₁₆	13 ¹⁵ / ₁₆	5	6 ³ / ₈	5	6	3	6	5	6 ¹¹ / ₃₂	14
40 x 12	40 ⁵ / ₈ x 12 ³ / ₁₆	42 ¹¹ / ₁₆	13 ¹⁵ / ₁₆	5	6 ³ / ₈	5	6	3	6	7	6 ¹¹ / ₃₂	18
50 x 12	50 ⁵ / ₈ x 12 ³ / ₁₆	52 ¹¹ / ₁₆	13 ¹⁵ / ₁₆	5	6 ³ / ₈	5	6	3	6	9	6 ¹¹ / ₃₂	22
60 x 12	60 ⁵ / ₈ x 12 ³ / ₁₆	62 ¹¹ / ₁₆	13 ¹⁵ / ₁₆	5	6 ³ / ₈	5	6	3	6	11	6 ¹¹ / ₃₂	26
70 x 12	70 ⁵ / ₈ x 12 ³ / ₁₆	72 ¹¹ / ₁₆	13 ¹⁵ / ₁₆	5	6 ³ / ₈	5	6	3	6	13	6 ¹¹ / ₃₂	30
15 x 15	15 ⁵ / ₈ x 15 ³ / ₁₆	17 ¹¹ / ₁₆	17	5	9 ¹³ / ₁₆	5	9	3 ¹³ / ₁₆	8 ¹ / ₈	2	6 ¹¹ / ₃₂	8
20 x 15	20 ⁵ / ₈ x 15 ³ / ₁₆	22 ¹¹ / ₁₆	17	5	9 ¹³ / ₁₆	5	9	3 ¹³ / ₁₆	8 ¹ / ₈	3	6 ¹¹ / ₃₂	10
25 x 15	25 ⁵ / ₈ x 15 ³ / ₁₆	27 ¹¹ / ₁₆	17	5	9 ¹³ / ₁₆	5	9	3 ¹³ / ₁₆	8 ¹ / ₈	4	6 ¹¹ / ₃₂	12
30 x 15	30 ⁵ / ₈ x 15 ³ / ₁₆	32 ¹¹ / ₁₆	17	5	9 ¹³ / ₁₆	5	9	3 ¹³ / ₁₆	8 ¹ / ₈	5	6 ¹¹ / ₃₂	14
40 x 15	40 ⁵ / ₈ x 15 ³ / ₁₆	42 ¹¹ / ₁₆	17	5	9 ¹³ / ₁₆	5	9	3 ¹³ / ₁₆	8 ¹ / ₈	7	6 ¹¹ / ₃₂	18
50 x 15	50 ⁵ / ₈ x 15 ³ / ₁₆	52 ¹¹ / ₁₆	17	5	9 ¹³ / ₁₆	5	9	3 ¹³ / ₁₆	8 ¹ / ₈	9	6 ¹¹ / ₃₂	22
60 x 15	60 ⁵ / ₈ x 15 ³ / ₁₆	62 ¹¹ / ₁₆	17	5	9 ¹³ / ₁₆	5	9	3 ¹³ / ₁₆	8 ¹ / ₈	11	6 ¹¹ / ₃₂	26
70 x 15	70 ⁵ / ₈ x 15 ³ / ₁₆	72 ¹¹ / ₁₆	17	5	9 ¹³ / ₁₆	5	9	3 ¹³ / ₁₆	8 ¹ / ₈	13	6 ¹¹ / ₃₂	30

Note: Model DL-SV drum louver can be operated at high discharge velocities. However, if at these velocities the static pressure across the drum louver itself is more than 0.25" wg, the optional opposed-blade damper becomes ineffective and is therefore not recommended.

DL AND DL-SV / 15° UP

Min. Duct Area sq. ft.	Listed Size, Inches	Duct Velocity fpm	NC 20			NC 30			NC 40	
			300	400	500	600	700	800	900	1000
0.43	9X6	Vel. Press., in. wg.	0.006	0.010	0.016	0.022	0.031	0.040	0.050	0.062
		cfm	129	172	215	258	301	344	387	430
		NC (Noise Criteria)	<10	<10	17	23	29	34	38	42
		Total Press., in. wg	0.05	0.08	0.13	0.18	0.25	0.32	0.41	0.51
0.83	18X6	Throw, ft.	5-6-16	7-11-22	9-14-26	11-16-29	13-19-31	15-22-33	16-25-35	18-26-37
		cfm	250	333	416	500	583	666	749	833
		NC (Noise Criteria)	<10	11	19	25	31	35	40	43
		Total Press., in. wg	0.05	0.08	0.13	0.18	0.25	0.32	0.41	0.51
1.37	30X6	Throw	11-16-28	14-21-33	18-26-37	21-28-40	25-31-43	27-33-46	28-35-49	30-37-52
		cfm	411	548	685	821	958	1095	1232	1369
		NC (Noise Criteria)	<10	10	18	24	29	34	38	42
		Total Press., in. wg	0.05	0.08	0.13	0.18	0.25	0.32	0.41	0.51
2.71	60X6	Throw, ft.	17-26-37	23-30-42	27-33-47	30-37-52	32-39-56	34-42-60	37-45-63	38-47-67
		cfm	813	1084	1355	1626	1897	2168	2439	2710
		NC (Noise Criteria)	<10	16	23	30	35	40	44	48
		Total Press., in. wg	0.05	0.08	0.13	0.18	0.25	0.32	0.41	0.51
1.46	20X10	Throw, ft.	30-36-51	34-42-59	38-47-66	42-51-73	45-55-78	48-59-84	51-63-89	54-66-94
		cfm	438	584	730	875	1021	1167	1313	1459
		NC (Noise Criteria)	<10	13	20	26	31	36	40	44
		Total Press.	0.03	0.05	0.09	0.12	0.17	0.22	0.28	0.34
3.58	50X10	Throw	18-27-38	25-31-44	28-34-49	31-38-53	33-41-58	36-44-62	38-46-65	40-49-69
		cfm	1074	1433	1791	2149	2507	2865	3223	3582
		NC (Noise Criteria)	<10	16	23	29	35	40	44	48
		Total Press., in. wg	0.03	0.05	0.09	0.12	0.17	0.22	0.28	0.34
5.00	70X10	Throw, ft.	34-42-59	39-48-68	44-54-76	48-59-84	52-64-90	56-68-96	59-72-102	62-76-108
		cfm	1499	1999	2498	2998	3498	3997	4497	4996
		NC (Noise Criteria)	<10	18	25	31	36	41	45	49
		Total Press., in. wg	0.03	0.05	0.09	0.12	0.17	0.22	0.28	0.34
1.75	20X12	Throw, ft.	40-49-70	47-57-81	52-64-90	57-70-99	62-75-107	66-81-114	70-85-121	74-90-127
		cfm	524	698	873	1047	1222	1396	1571	1746
		NC (Noise Criteria)	<10	13	20	27	32	37	41	45
		Total Press.	0.03	0.05	0.08	0.11	0.16	0.20	0.26	0.32
3.44	40X12	Throw	22-29-41	27-34-48	31-38-53	34-41-58	36-45-63	39-48-67	41-50-71	43-53-75
		cfm	1031	1375	1719	2063	2407	2751	3094	3438
		NC (Noise Criteria)	<10	16	23	29	35	39	44	47
		Total Press.	0.03	0.05	0.08	0.11	0.16	0.20	0.26	0.32
5.98	70X12	Throw, ft.	33-41-58	39-47-67	43-53-75	47-58-82	51-62-88	55-67-94	58-71-100	61-75-106
		cfm	1793	2391	2989	3586	4184	4782	5380	5977
		NC (Noise Criteria)	<10	19	26	32	37	42	46	50
		Total Press., in. wg	0.03	0.05	0.08	0.11	0.16	0.20	0.26	0.32
1.65	15X15	Throw, ft.	44-54-76	51-62-88	57-70-98	62-76-108	67-82-117	72-88-125	76-93-132	80-98-139
		cfm	494	659	824	989	1154	1318	1483	1648
		NC (Noise Criteria)	<10	13	20	27	32	37	41	45
		Total Press.	0.02	0.04	0.07	0.10	0.13	0.17	0.22	0.27
5.34	50X15	Throw, ft.	19-28-40	25-33-46	30-37-52	33-40-57	35-43-61	38-46-65	40-49-69	42-52-73
		cfm	1602	2136	2670	3204	3738	4271	4805	5339
		NC (Noise Criteria)	<10	18	25	31	36	41	45	49
		Total Press.	0.02	0.04	0.07	0.10	0.13	0.17	0.22	0.27
7.45	70X15	Throw	42-51-72	48-59-83	54-66-93	59-72-102	64-78-110	68-83-118	72-88-125	76-93-132
		cfm	2235	2979	3724	4469	5214	5959	6704	7449
		NC (Noise Criteria)	10	19	27	32	38	43	47	51
		Total Press., in. wg	0.02	0.04	0.07	0.10	0.13	0.17	0.22	0.27
		Throw, ft.	49-60-85	57-70-98	63-78-110	70-85-120	75-92-130	80-98-139	85-104-148	90-110-155

NC 50

- All data is based on tests conducted in accordance with ANSI/ASHRAE Standard 70-2006
- Throw is based on isothermal air, 150, 100 and 50 fpm terminal velocities. See the section, Engineering Guidelines, in this catalog for throw information.
- Velocity Pressures are based on nominal duct velocity
- Listed size is slightly less than the minimum allowed duct dimensions. (see pages I57-I58 for actual duct dimension)
- Each NC value represents the noise criterion that will not be exceeded by the sound pressure in any of the octave bands, 2nd through 7th. Each NC value is based on a room absorption of 10dB, re 10⁻¹² watts.
- Throw is based on a 15° upward deflection. For 0° upward deflection multiply throw values shown by 1.2. For 30° upward deflection multiply throw values shown by 0.8.

Variable Air Volume Applications

Deflection	Throw	Total Pressure	NC
0°	1.2	0.8	-4
30°	0.8	1.43	+4

- All Titus supply grilles can be applied to variable air volume systems with excellent results. For detailed selection methods, consult your Titus representative or the Engineering Guidelines section of this catalog.

S-DL / S-DL-SV

- Well suited for installations where the conditioned space is large and it is impractical to bring the duct work close to the occupants
- Models S-DL and S-DL-SV mount directly to spiral duct eliminating the need for duct taps and reducing installation costs and time
- Optional split-vane option allows bi-directional horizontal throw
- Great for applications requiring high air volumes or long throws
- Length of throw, plus horizontal and vertical direction, can be adjusted by means of the rotating drum and pivoted adjustable blades
- Felt seal between the drum and border frame prevents leakage and holds the drum securely in the position selected
- 2-blade spacing option

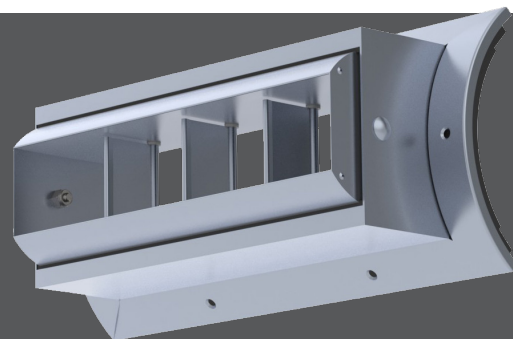

S-DL / S-DL-SV



duct mounted factories gymnasiums open areas airport terminals

 See website for Specifications

AVAILABLE MODELS:

- S-DL / Single Vane / Universal End Cap
- S-DL-SV / Split Vane / Universal End Cap

FINISHES

- Standard Finish - #26 White
- Optional Finishes - #01 Aluminum or #84 Black

OVERVIEW

High Capacity / Long Throw

The Titus S-DL drum louvers have a custom curved frame to attach to a variety of duct diameters without the use of a duct tap. They are great for shopping malls, warehouses, sports arenas, factories and other large open areas where air must be thrown over a large distance. The high capacity long throws and rugged construction make them an ideal choice for any commercial / industrial application.

PRODUCTS INCLUDE

- Material: Aluminum extruded border and blades
- Optional air extractor or heavy-duty damper with a screwdriver operator accessible through the face
- Foam gaskets for tight seal to spiral duct



Installation images of the S-DL drum louver installed in an open ceiling environment

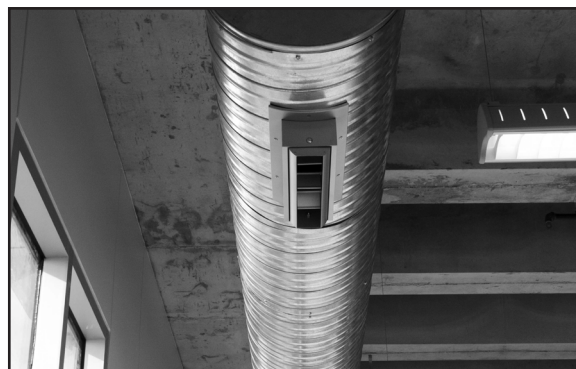

S-DL / S-DL-SV DIMENSIONS

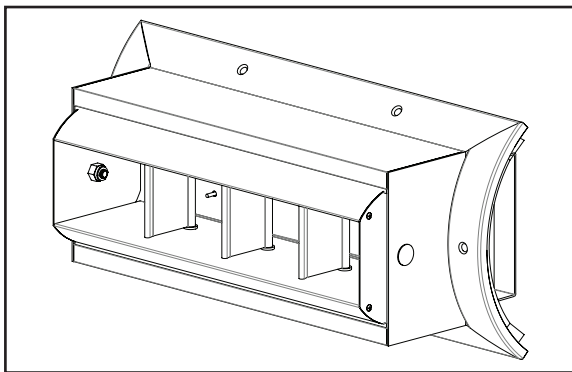
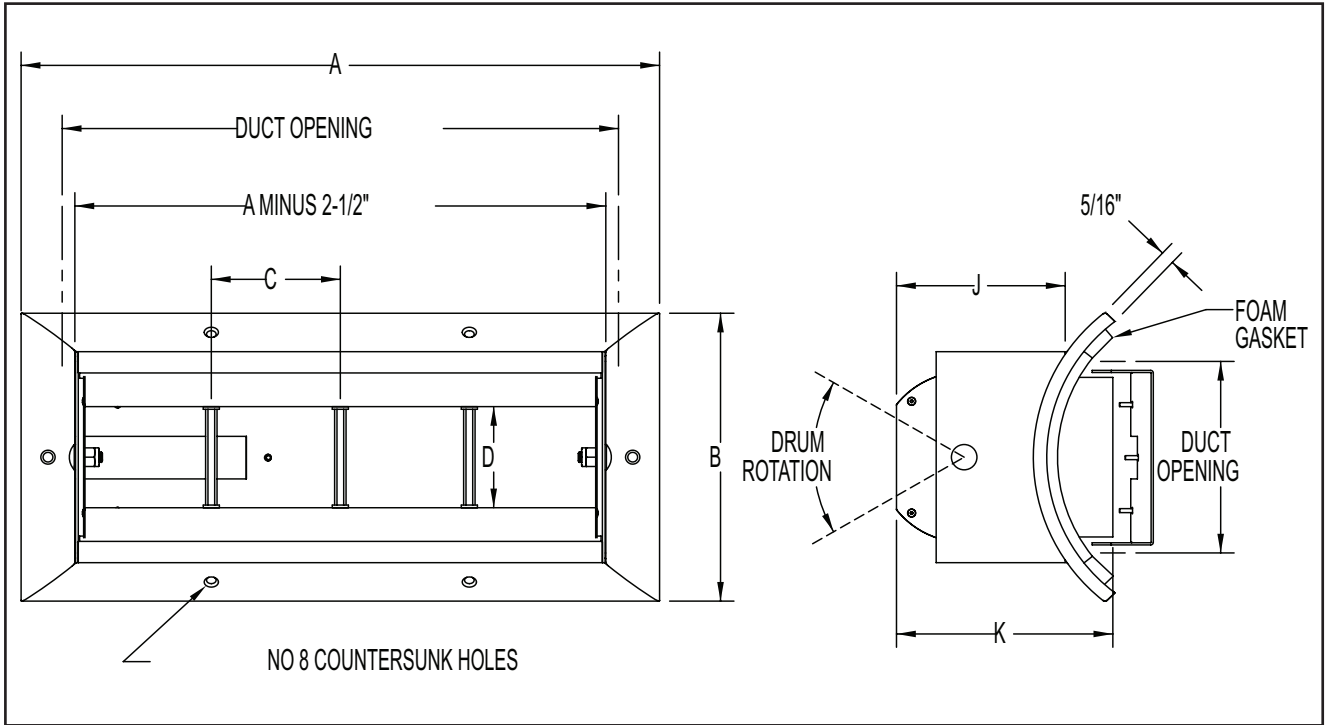

Above: S-DL / Single Vane

Below: S-DL-SV / Split Vane Option

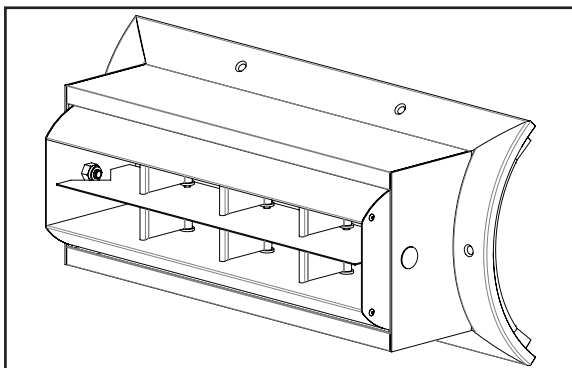

DIMENSIONS

S-DL / S-DL-SV DIMENSIONS

Model AG-15-HD Opposed Blade Damper

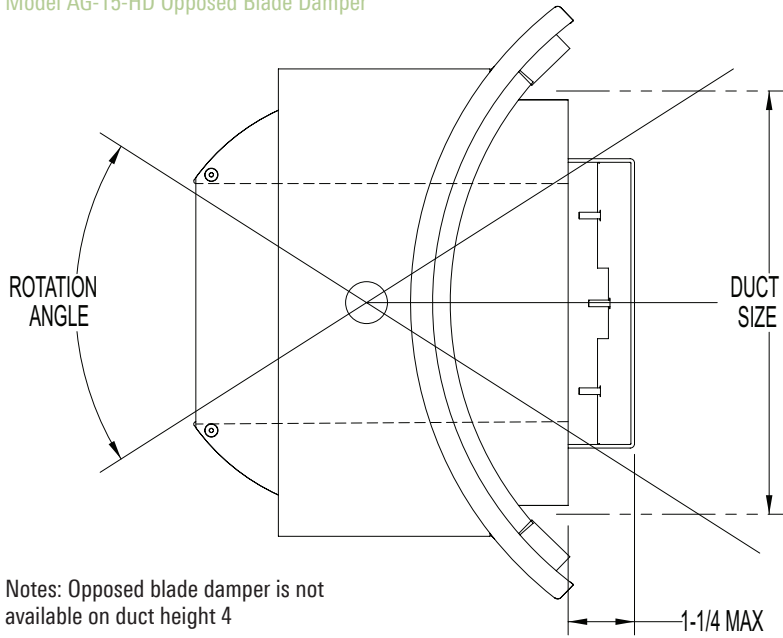

Duct Size D	With Damper	Without Damper
4	N/A	30
6	19	27
8	18	26
10	27	27
12	26	26
15	27	27

Notes: Opposed blade damper is not available on duct height 4

Model ASD Air Scoop Volume Extractor

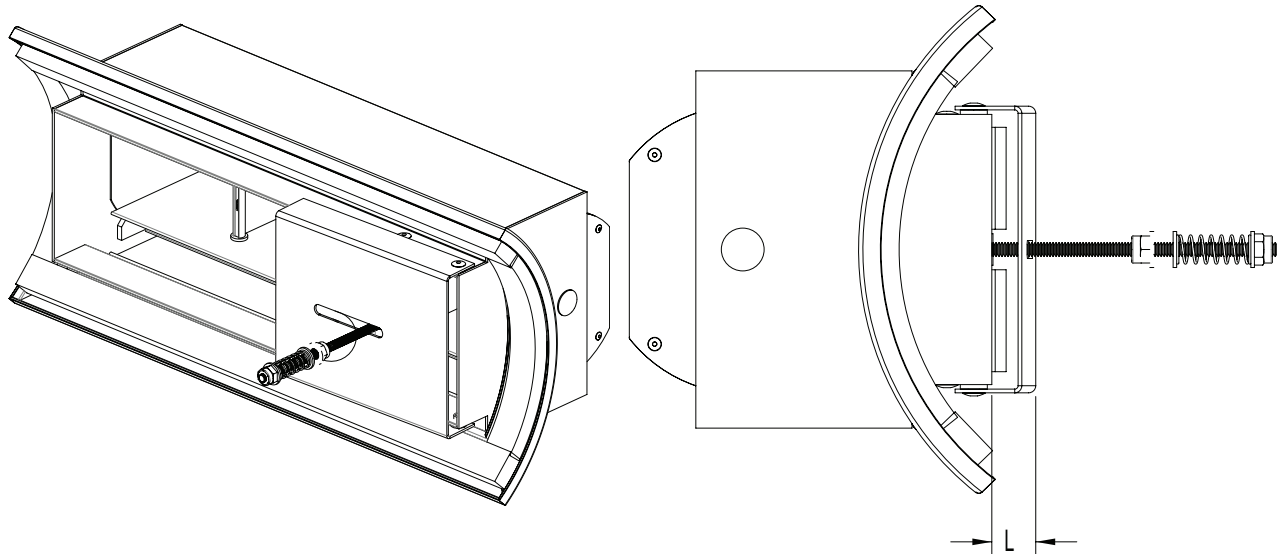

S-DL / S-DL-SV DIMENSIONS

Listed Size (L x H)	B (MAX)	A	C ₁	C ₂	D	J	K	L (MAX)	Minimum Duct Dia.	Blade QTY ₁	Blade QTY ₂	Mounting Hole QTY	Duct Opening
12 x 4	6½	14⅞	3	2	2⅜	3 ¹⁵ / ₁₆	5 ¹ / ₃₂	3⅜	8	3	6	6	12½ x 4½
18 x 4	6½	20⅞	3	2	2⅜	3 ¹⁵ / ₁₆	5 ¹ / ₃₂	3⅜	8	5	9	8	18½ x 4½
24 x 4	6½	26⅞	3	2	2⅜	3 ¹⁵ / ₁₆	5 ¹ / ₃₂	3⅜	8	7	12	10	24½ x 4½
30 x 4	6½	32⅞	3	2	2⅜	3 ¹⁵ / ₁₆	5 ¹ / ₃₂	3⅜	8	9	15	12	30½ x 4½
36 x 4	6½	38⅞	3	2	2⅜	3 ¹⁵ / ₁₆	5 ¹ / ₃₂	3⅜	8	11	18	14	36½ x 4½
42 x 4	6½	44⅞	3	2	2⅜	3 ¹⁵ / ₁₆	5 ¹ / ₃₂	3⅜	8	13	21	16	42½ x 4½
48 x 4	6½	50⅞	3	2	2⅜	3 ¹⁵ / ₁₆	5 ¹ / ₃₂	3⅜	8	15	24	18	48½ x 4½
60 x 4	8½	62⅞	3	2	2⅜	3 ¹⁵ / ₁₆	5 ¹ / ₃₂	3⅜	8	19	30	20	60½ x 4½
12 x 6	8½	14⅞	3	2	3⅜	4 ³ / ₃₂	5 ³ / ₃₂	4 ¹ / ₃₂	10	3	6	6	12½ x 6½
18 x 6	8½	20⅞	3	2	3⅜	4 ³ / ₃₂	5 ³ / ₃₂	4 ¹ / ₃₂	10	5	9	8	18½ x 6½
24 x 6	8½	26⅞	3	2	3⅜	4 ³ / ₃₂	5 ³ / ₃₂	4 ¹ / ₃₂	10	7	12	10	24½ x 6½
30 x 6	8½	32⅞	3	2	3⅜	4 ³ / ₃₂	5 ³ / ₃₂	4 ¹ / ₃₂	10	9	15	12	30½ x 6½
36 x 6	8½	38⅞	3	2	3⅜	4 ³ / ₃₂	5 ³ / ₃₂	4 ¹ / ₃₂	10	11	18	14	36½ x 6½
42 x 6	8½	44⅞	3	2	3⅜	4 ³ / ₃₂	5 ³ / ₃₂	4 ¹ / ₃₂	10	13	21	16	42½ x 6½
48 x 6	8½	50⅞	3	2	3⅜	4 ³ / ₃₂	5 ³ / ₃₂	4 ¹ / ₃₂	10	15	24	18	48½ x 6½
60 x 6	8½	62⅞	3	2	3⅜	4 ³ / ₃₂	5 ³ / ₃₂	4 ¹ / ₃₂	10	19	30	20	60½ x 6½
12 x 8	10½	14⅞	3	2	4⅜	5⅞	6¾	5 ¹ / ₃₂	12	3	6	6	12½ x 8½
18 x 8	10½	20⅞	3	2	4⅜	5⅞	6¾	5 ¹ / ₃₂	12	5	9	8	18½ x 8½
24 x 8	10½	26⅞	3	2	4⅜	5⅞	6¾	5 ¹ / ₃₂	12	7	12	10	24½ x 8½
30 x 8	10½	32⅞	3	2	4⅜	5⅞	6¾	5 ¹ / ₃₂	12	9	15	12	30½ x 8½
36 x 8	10½	38⅞	3	2	4⅜	5⅞	6¾	5 ¹ / ₃₂	12	11	18	14	36½ x 8½
42 x 8	10½	44⅞	3	2	4⅜	5⅞	6¾	5 ¹ / ₃₂	12	13	21	16	42½ x 8½
48 x 8	10½	50⅞	3	2	4⅜	5⅞	6¾	5 ¹ / ₃₂	12	15	24	18	48½ x 8½
60 x 8	10½	62⅞	3	2	4⅜	5⅞	6¾	5 ¹ / ₃₂	12	19	30	20	60½ x 8½
12 x 10	12½	14⅞	5	2	5⅞	7⅞	8 ³ / ₃₂	6 ² / ₃₂	14	2	6	6	12½ x 10½
18 x 10	12½	20⅞	5	2	5⅞	7⅞	8 ³ / ₃₂	6 ² / ₃₂	14	3	9	8	18½ x 10½
24 x 10	12½	26⅞	5	2	5⅞	7⅞	8 ³ / ₃₂	6 ² / ₃₂	14	4	12	10	24½ x 10½
30 x 10	12½	32⅞	5	2	5⅞	7⅞	8 ³ / ₃₂	6 ² / ₃₂	14	5	15	12	30½ x 10½
36 x 10	12½	38⅞	5	2	5⅞	7⅞	8 ³ / ₃₂	6 ² / ₃₂	14	6	18	14	36½ x 10½
42 x 10	12½	44⅞	5	2	5⅞	7⅞	8 ³ / ₃₂	6 ² / ₃₂	14	8	21	16	42½ x 10½
48 x 10	12½	50⅞	5	2	5⅞	7⅞	8 ³ / ₃₂	6 ² / ₃₂	14	9	24	18	48½ x 10½
60 x 10	12½	62⅞	5	2	5⅞	7⅞	8 ³ / ₃₂	6 ² / ₃₂	14	11	30	20	60½ x 10½
12 x 12	14½	14⅞	5	2	6⅞	7 ¹³ / ₁₆	8 ²⁹ / ₃₂	7 ³ / ₃₂	16	2	6	6	12½ x 12½
18 x 12	14½	20⅞	5	2	6⅞	7 ¹³ / ₁₆	8 ²⁹ / ₃₂	7 ³ / ₃₂	16	3	9	8	18½ x 12½
24 x 12	14½	26⅞	5	2	6⅞	7 ¹³ / ₁₆	8 ²⁹ / ₃₂	7 ³ / ₃₂	16	4	12	10	24½ x 12½
30 x 12	14½	32⅞	5	2	6⅞	7 ¹³ / ₁₆	8 ²⁹ / ₃₂	7 ³ / ₃₂	16	5	15	12	30½ x 12½
36 x 12	14½	38⅞	5	2	6⅞	7 ¹³ / ₁₆	8 ²⁹ / ₃₂	7 ³ / ₃₂	16	6	18	14	36½ x 12½
42 x 12	14½	44⅞	5	2	6⅞	7 ¹³ / ₁₆	8 ²⁹ / ₃₂	7 ³ / ₃₂	16	8	21	16	42½ x 12½
48 x 12	14½	50⅞	5	2	6⅞	7 ¹³ / ₁₆	8 ²⁹ / ₃₂	7 ³ / ₃₂	16	9	24	18	48½ x 12½
60 x 12	14½	62⅞	5	2	6⅞	7 ¹³ / ₁₆	8 ²⁹ / ₃₂	7 ³ / ₃₂	16	11	30	20	60½ x 12½
12 x 15	17½	14⅞	5	2	9 ¹³ / ₁₆	8 ¹³ / ₃₂	9½	10 ¹ / ₁₆	20	2	6	6	12½ x 15½
18 x 15	17½	20⅞	5	2	9 ¹³ / ₁₆	8 ¹³ / ₃₂	9½	10 ¹ / ₁₆	20	3	9	8	18½ x 15½
24 x 15	17½	26⅞	5	2	9 ¹³ / ₁₆	8 ¹³ / ₃₂	9½	10 ¹ / ₁₆	20	4	12	10	24½ x 15½
30 x 15	17½	32⅞	5	2	9 ¹³ / ₁₆	8 ¹³ / ₃₂	9½	10 ¹ / ₁₆	20	5	15	12	30½ x 15½
36 x 15	17½	38⅞	5	2	9 ¹³ / ₁₆	8 ¹³ / ₃₂	9½	10 ¹ / ₁₆	20	6	18	14	36½ x 15½
42 x 15	17½	44⅞	5	2	9 ¹³ / ₁₆	8 ¹³ / ₃₂	9½	10 ¹ / ₁₆	20	8	21	16	42½ x 15½
48 x 15	17½	50⅞	5	2	9 ¹³ / ₁₆	8 ¹³ / ₃₂	9½	10 ¹ / ₁₆	20	9	24	18	48½ x 15½
60 x 15	17½	62⅞	5	2	9 ¹³ / ₁₆	8 ¹³ / ₃₂	9½	10 ¹ / ₁₆	20	11	30	20	60½ x 15½

Notes:

- Minimum duct diameters for each unit height are listed
- Diameters may be specified in 2" increments to a maximum duct diameter of 36
- Unit may be selected with C1 or C2 blade spacing

S-DL / S-DL-SV 4"

Min. Duct Area sq. ft.	Listed Size, Inches	Duct Velocity fpm	300	400	500	600	700	800	900	1000
		Vel. Press, in wg.	0.006	0.010	0.016	0.022	0.031	0.040	0.050	0.062
0.33	12 x 4	cfm	100	123	166	200	233	266	300	333
		NC (Noise Criteria)	-	-	-	15	19	31	37	41
		Total Pressure, in. wg.	0.04	0.06	0.10	0.14	0.19	0.26	0.32	0.40
		Throw, ft.	10-13-20	13-16-23	15-18-26	16-19-29	18-21-31	19-22-33	20-23-36	21-25-38
		cfm	150	200	250	300	350	400	450	500
0.50	18 x 4	cfm	150	200	250	300	350	400	450	500
		NC (Noise Criteria)	-	-	-	19	26	34	37	43
		Total Pressure, in. wg.	0.03	0.05	0.07	0.11	0.15	0.20	0.25	0.31
		Throw, ft.	14-16-23	16-19-27	18-21-31	19-23-34	21-25-36	22-27-39	24-29-41	25-30-43
		cfm	200	266	333	400	466	535	600	665
0.66	24 x 4	cfm	200	266	333	400	466	535	600	665
		NC (Noise Criteria)	-	-	10	20	27	35	38	44
		Total Pressure, in. wg.	0.03	0.05	0.10	0.11	0.15	0.20	0.25	0.31
		Throw, ft.	16-19-27	18-22-32	20-24-26	23-27-39	24-29-42	27-31-45	28-33-49	29-35-51
		cfm	250	333	415	500	583	665	750	830
0.83	30 x 4	cfm	250	333	415	500	583	665	750	830
		NC (Noise Criteria)	-	-	12	22	28	35	39	46
		Total Pressure, in. wg.	0.03	0.05	0.07	0.11	0.15	0.20	0.25	0.33
		Throw, ft.	18-21-31	20-24-35	23-28-40	25-30-44	28-33-47	29-35-51	31-37-54	32-39-56
		cfm	300	400	500	600	700	800	900	1000
1.00	36 x 4	cfm	300	400	500	600	700	800	900	1000
		NC (Noise Criteria)	-	-	13	23	30	37	41	47
		Total Pressure, in. wg.	0.03	0.05	0.07	0.11	0.15	0.20	0.25	0.31
		Throw, ft.	19-23-33	22-26-38	25-30-43	27-33-48	29-35-51	31-38-55	33-40-58	35-42-62
		cfm	350	465	583	700	815	933	1050	1160
1.16	42 x 4	cfm	350	465	583	700	815	933	1050	1160
		NC (Noise Criteria)	-	-	14	25	32	38	42	49
		Total Pressure, in. wg.	0.03	0.05	0.07	0.11	0.15	0.20	0.25	0.31
		Throw, ft.	21-25-36	24-28-42	26-32-47	29-35-51	32-38-56	34-41-60	36-43-64	38-46-67
		cfm	400	533	665	800	933	1065	1200	1330
1.33	48 x 4	cfm	400	533	665	800	933	1065	1200	1330
		NC (Noise Criteria)	-	-	15	25	32	38	42	50
		Total Pressure, in. wg.	0.03	0.05	0.07	0.11	0.15	0.20	0.25	0.31
		Throw, ft.	22-27-39	26-31-45	28-35-50	32-39-55	34-42-60	36-45-64	38-47-66	40-50-71
		cfm	500	665	833	1000	1160	1330	1500	1660
1.66	60 x 4	cfm	500	665	833	1000	1160	1330	1500	1660
		NC (Noise Criteria)	-	-	16	26	35	39	43	50
		Total Pressure, in. wg.	0.03	0.05	0.07	0.11	0.15	0.20	0.25	0.31
		Throw, ft.	26-30-43	29-34-50	33-39-56	36-43-61	39-45-66	41-49-71	43-52-75	47-55-80
		cfm	500	665	833	1000	1160	1330	1500	1660

S-DL / S-DL-SV 8"

Min. Duct Area sq. ft.	Listed Size, Inches	Duct Velocity fpm	300	400	500	600	700	800	900	1000
		Vel. Press, in wg.	0.006	0.010	0.016	0.022	0.031	0.040	0.050	0.062
0.66	12 x 8	cfm	200	266	333	400	465	533	600	665
		NC (Noise Criteria)	-	-	-	19	27	33	40	45
		Total Pressure, in. wg.	0.04	0.06	0.09	0.13	0.18	0.24	0.30	0.37
		Throw, ft.	12-19-28	16-22-32	19-24-36	22-26-39	23-28-42	25-36-45	28-32-49	29-35-50
		cfm	300	400	500	600	700	800	900	1000
1.00	18 x 8	cfm	300	400	500	600	700	800	900	1000
		NC (Noise Criteria)	-	-	-	19	26	34	37	43
		Total Pressure, in. wg.	0.04	0.06	0.10	0.14	0.20	0.26	0.32	0.40
		Throw, ft.	18-23-33	21-26-38	24-29-42	27-32-47	29-34-50	31-37-54	33-39-58	34-41-60
		cfm	400	533	665	800	933	1065	1200	1333
1.33	24 x 8	cfm	400	533	665	800	933	1065	1200	1333
		NC (Noise Criteria)	-	-	13	22	30	37	43	48
		Total Pressure, in. wg.	0.04	0.06	0.10	0.14	0.20	0.26	0.32	0.40
		Throw, ft.	21-26-39	25-30-44	27-34-49	31-37-54	33-40-59	35-43-63	38-46-66	40-49-70
		cfm	500	665	833	1000	1165	1333	1500	1665
1.66	30 x 8	cfm	500	665	833	1000	1165	1333	1500	1665
		NC (Noise Criteria)	-	-	15	25	32	38	44	49
		Total Pressure, in. wg.	0.04	0.06	0.10	0.14	0.20	0.26	0.32	0.40
		Throw, ft.	24-29-43	28-34-50	31-38-55	33-42-60	36-45-66	38-49-70	41-52-74	43-55-79
		cfm	600	800	1000	1200	1400	1600	1800	2000
2.00	36 x 8	cfm	600	800	1000	1200	1400	1600	1800	2000
		NC (Noise Criteria)	-	-	16	26	33	40	45	50
		Total Pressure, in. wg.	0.04	0.07	0.11	0.15	0.22	0.28	0.35	0.44
		Throw, ft.	27-32-47	31-37-54	35-41-60	38-45-66	41-49-71	43-52-76	46-55-81	48-59-85
		cfm	700	933	1165	1400	1633	1865	2100	2335
2.33	42 x 8	cfm	700	933	1165	1400	1633	1865	2100	2335
		NC (Noise Criteria)	-	-	16	27	34	41	46	51
		Total Pressure, in. wg.	0.04	0.07	0.11	0.15	0.22	0.28	0.35	0.44
		Throw, ft.	28-34-50	32-39-58	36-44-64	39-48-70	43-52-76	46-56-82	48-59-87	50-62-92
		cfm	400	533	665	800	933	1065	1200	1330
2.66	48 x 8	cfm	400	533	665	800	933	1065	1200	1330
		NC (Noise Criteria)	-	-	17	27	35	42	47	51
		Total Pressure, in. wg.	0.04	0.07	0.11	0.15	0.22	0.28	0.35	0.44
		Throw, ft.	3-37-55	35-43-63	40-47-70	43-50-77	47-57-84	50-60-90	53-64-95	56-68-100
		cfm	1000	1335	1665	2000	2335	2665	3000	3335
3.33	60 x 8	cfm	1000	1335	1665	2000	2335	2665	3000	3335
		NC (Noise Criteria)	-	-	18	28	35	42	48	52
		Total Pressure, in. wg.	0.04	0.07	0.11	0.15	0.22	0.28	0.35	0.44
		Throw, ft.	32-41-61	38-47-70	42-53-79	46-59-85	50-63-92	54-67-98	57-72-105	60-75-111
		cfm	1000	1335	1665	2000	2335	2665	3000	3335

US-DL / US-DL-SV

- Models US-DL and US-DL-SV mount directly to spiral duct eliminating the need for duct taps and reducing installation costs and time
- US-DL-SV drum louvers employ a split vane design to produce diverging air streams
- Great for applications requiring high air volumes or long throws
- Length of throw, plus horizontal and vertical direction, can be adjusted by means of the rotating drum and pivoted adjustable blades
- Felt seal between the drum and border frame prevents leakage and holds the drum securely in the position selected
- Air scoop damper (ASD) or heavy duty opposed blade damper (AG-50-HD) available as options. AG-50-HD has screwdriver operator accessible through discharge opening of the drum louver.

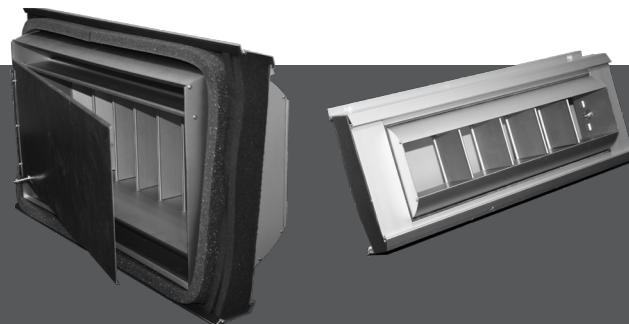

US-DL / US-DL-SV

Redefine your comfort zone™ | www.titus-hvac.com



duct mounted

factories

gymnasiums

open areas

airport terminals

AVAILABLE MODELS:

- US-DL / Single Vane / Universal End Cap
- US-DL-SV / Split Vane / Universal End Cap



See website for Specifications

FINISHES

Standard Finish - #26 White or #34 Clear Anodize

OVERVIEW

High Capacity / Long Throw

Titus Models US-DL & US-DL-SV drum louvers are especially useful where long throws are required. This requirement occurs in installations where the conditioned space is large, making it impractical to bring the ductwork close to the occupants. Examples of such installations are shopping malls, coliseums, field houses, air terminals, factories and warehouses.

PRODUCTS INCLUDE

- Material: Aluminum extruded border and blades
- Universal end cap design to fit multiple spiral duct diameters
- Foam gaskets for tight seal to spiral duct

US-DL / US-DL-SV

DIMENSIONS

US-DL / US-DL-SV DIMENSIONS

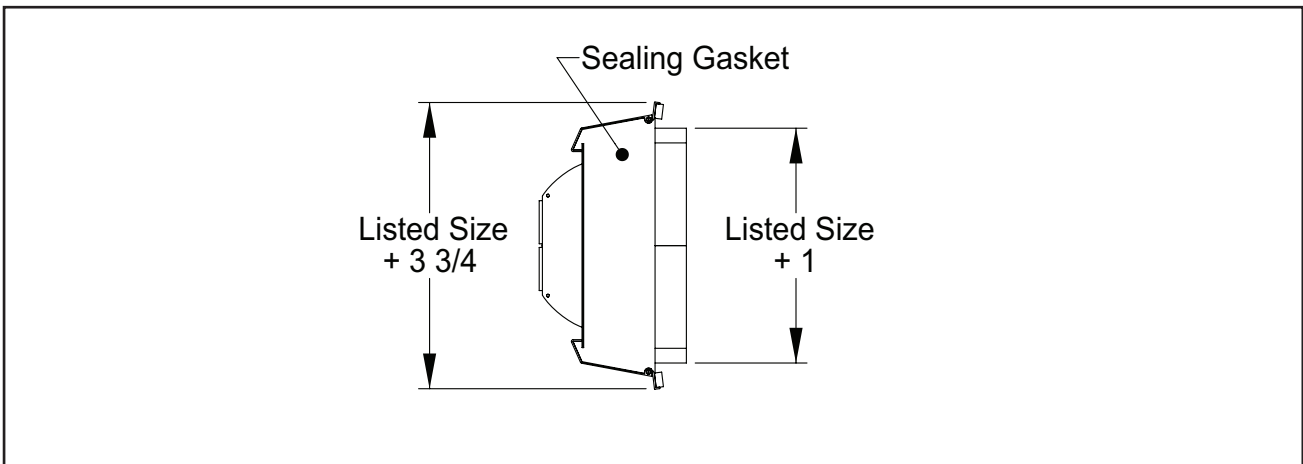
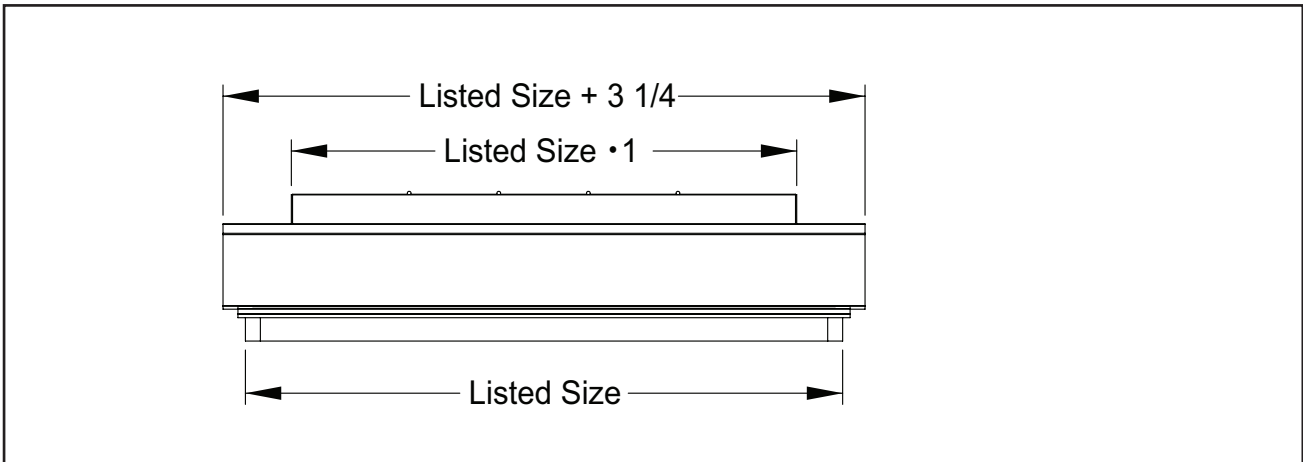
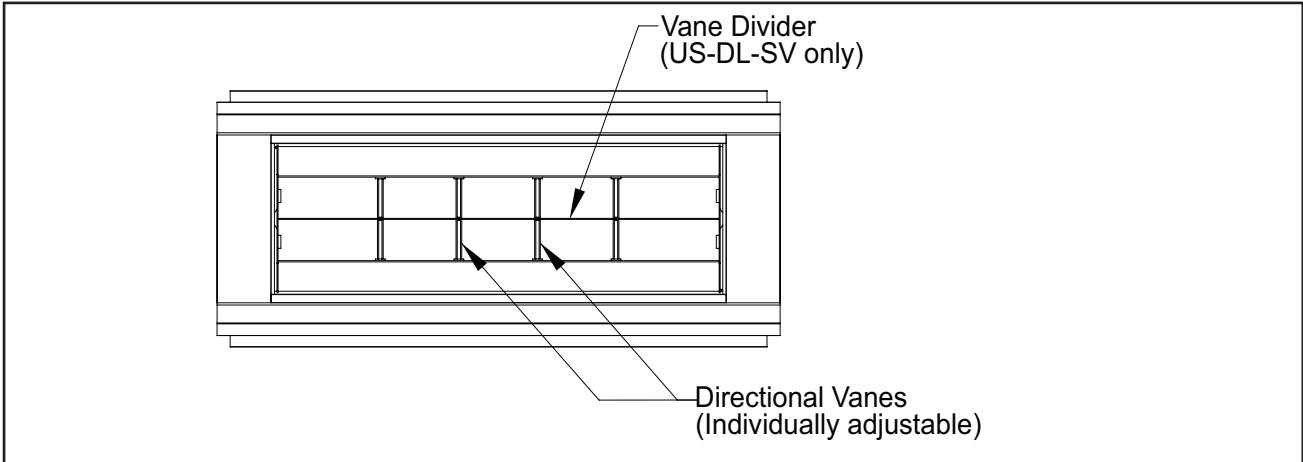

Diffuser with	6	10	12	15
Spiral Duct Diameter (Min/Max)	12 / 65	24 / 97	24 / 112	36 / 145

Available Sizes:
Width: 6", 10", 12", 15"
Length: 6" through 48" in 1" increments
(fractional sizes are not available)

US-DL / US-DL-SV - DRUM AT 0° DEFLECTION AND NO SPREAD

6" HEIGHT

Size	Neck Velocity (fpm)	300	400	500	600	700	800	900	1000
	Velocity Pressure	0.006	0.010	0.016	0.022	0.031	0.040	0.050	0.062
Total Pressure	0.050	0.080	0.130	0.160	0.250	0.320	0.410	0.510	
12 x 6	Airflow, cfm	160	215	270	325	380	430	485	540
	NC (Noise Criteria)	-	12	19	25	30	33	37	40
	Throw	7-10-19	9-14-22	12-18-25	14-19-28	17-21-30	18-22-32	19-24-34	20-25-35
18 x 6	Airflow, cfm	240	325	405	485	565	650	730	810
	NC (Noise Criteria)	-	14	21	27	32	35	39	42
	Throw	9-13-24	12-17-26	14-22-30	17-24-33	21-26-36	23-28-38	25-30-40	26-32-44
24 x 6	Airflow, cfm	325	430	540	650	755	865	972	1040
	NC (Noise Criteria)	-	17	23	29	34	37	41	44
	Throw	10-15-28	13-20-32	17-25-35	20-28-39	23-30-42	26-32-45	27-34-48	28-35-49
36 x 6	Airflow, cfm	485	650	810	970	1135	1295	1460	1620
	NC (Noise Criteria)	10	18	24	30	35	38	42	45
	Throw	12-19-34	16-24-37	21-30-42	24-34-47	29-37-51	34-40-53	35-42-56	37-46-62

10" HEIGHT

Size	Neck Velocity (fpm)	300	400	500	600	700	800	900	1000
	Velocity Pressure	0.006	0.010	0.016	0.022	0.031	0.040	0.050	0.062
Total Pressure	0.030	0.050	0.090	0.120	0.170	0.220	0.280	0.340	
24 x 10	Airflow, cfm	525	700	875	1050	1225	1400	1575	1750
	NC (Noise Criteria)	10	18	25	30	34	39	42	46
	Throw	12-18-34	18-28-40	21-33-44	28-37-49	31-39-53	35-41-56	37-43-60	39-48-65
30 x 10	Airflow, cfm	657	876	1095	1314	1535	1750	1970	2190
	NC (Noise Criteria)	11	20	26	31	36	41	44	47
	Throw	14-21-40	19-28-43	24-35-49	28-40-55	34-43-59	39-46-62	41-48-65	43-53-72
36 x 10	Airflow, cfm	790	1050	1315	1580	1840	2105	2365	2630
	NC (Noise Criteria)	13	21	28	33	38	41	45	48
	Throw	15-23-44	21-31-47	26-39-53	31-44-60	37-47-65	42-50-68	45-53-71	47-58-79
44 x 10	Airflow, cfm	1060	1400	1750	2100	2450	2800	3150	3500
	NC (Noise Criteria)	14	22	29	34	39	42	46	49
	Throw	17-26-50	24-35-54	30-45-62	35-50-69	43-54-75	49-58-78	52-60-82	54-67-92

12" HEIGHT

Size	Neck Velocity (fpm)	300	400	500	600	700	800	900	1000
	Velocity Pressure	0.006	0.010	0.016	0.022	0.031	0.040	0.050	0.062
Total Pressure	0.030	0.050	0.090	0.120	0.170	0.220	0.280	0.340	
18 x 12	Airflow, cfm	470	625	780	935	1090	1250	1400	1560
	NC (Noise Criteria)	-	18	26	31	35	40	43	46
	Throw	12-18-34	16-24-36	20-30-41	24-34-46	29-37-50	33-39-52	35-41-55	37-45-61
24 x 12	Airflow, cfm	625	830	1040	1250	1455	1665	1870	2030
	NC (Noise Criteria)	12	19	27	32	36	40	44	47
	Throw	14-20-39	19-27-42	23-34-48	27-39-53	33-42-58	37-45-61	40-48-64	42-52-71
36 x 12	Airflow, cfm	940	1250	1560	1875	2185	2500	2810	3125
	NC (Noise Criteria)	13	21	28	33	38	42	45	48
	Throw	17-25-47	23-33-51	29-42-58	33-47-65	40-49-70	46-54-74	48-58-78	51-63-86
48 x 12	Airflow, cfm	1250	1665	2080	2495	2910	3330	3745	4160
	NC (Noise Criteria)	14	22	29	34	39	43	47	49
	Throw	18-28-55	26-39-59	33-49-65	39-55-75	47-59-82	53-63-86	56-67-90	60-73-100

15" HEIGHT

Size	Neck Velocity (fpm)	300	400	500	600	700	800	900	1000
	Velocity Pressure	0.006	0.010	0.016	0.022	0.031	0.040	0.050	0.062
Total Pressure	0.020	0.040	0.070	0.100	0.130	0.170	0.220	0.270	
24 x 15	Airflow, cfm	775	1030	1290	1550	1805	2065	2320	2580
	NC (Noise Criteria)	13	21	27	32	37	41	44	47
	Throw	15-22-43	21-30-46	26-38-53	30-43-59	37-46-64	42-50-67	44-53-71	46-58-79
30 x 15	Airflow, cfm	970	1290	1615	1940	2260	2585	2910	3230
	NC (Noise Criteria)	13	22	28	33	38	42	45	49
	Throw	17-25-49	23-34-52	29-43-59	34-49-67	41-52-72	47-56-76	49-60-83	52-65-88
36 x 15	Airflow, cfm	1160	1550	1935	2320	2710	3100	3485	3870
	NC (Noise Criteria)	15	23	29	34	39	43	47	50
	Throw	19-27-53	25-37-57	32-47-65	37-53-72	45-57-79	51-61-83	54-65-86	57-71-96
48 x 15	Airflow, cfm	1550	2065	2580	3100	3610	4130	4645	5160
	NC (Noise Criteria)	16	24	30	35	40	44	48	51
	Throw	21-32-61	30-43-66	37-54-75	43-61-84	52-65-91	59-70-95	63-75-100	66-82-111

PERFORMANCE NOTES

- Data obtained from tests conducted in accordance with ANSI/ASHRAE Standard 70-2006
- Throw values are in feet at terminal velocities of 150, 100 and 50 fpm at isothermal conditions. Throw values were measured with drum at 0° deflection and no spread.
- For an explanation of catalog throw data, see the Engineering Guidelines section of this catalog
- NC values based on octave band 2 to 7 sound power levels minus a room absorption of 10 dB
- Each NC value represents the noise criteria curve that will not be exceeded by the sound pressure in any of the octave bands, 2 through 7, with a room absorption of 10 dB, re 10-12 watts
- Dash (-) in space denotes an NC value of less than 10
- All pressures are given in inches of water
- Velocity pressure is based on inlet duct area and velocity
- To obtain static pressure, subtract velocity pressure from the total pressure
- Listed size is slightly less than the minimum allowed duct dimensions (refer to data page for actual duct dimensions)

Model Number	Type Grille	Type Deflection	Deflection Degrees	Blade Spacing	Border Type	OS	FR	#01 #04	#20 #21 #26	#84	#34 #94 #95 #96	C	DS	IS	FG	PF	PFA	PFAP	EQT	
50F	AL-Return	Eggcrate	N/A	1/2" x 1/2" x 1/2" 1/2" x 1/2" x 1" 1" x 1" x 1"	1	Y	Y	Y	Y	Y	N	N	Y	Y	Y	Y	N	N	Y	
50F	AL-Return	Eggcrate	N/A	1/2" x 1/2" x 1/2" 1/2" x 1/2" x 1" 1" x 1" x 1"	3	N	N	Y	Y	Y	N	N	Y	Y	N	N	N	N	Y	
50F	AL-Return	Eggcrate	N/A	1/2" x 1/2" x 1/2" 1/2" x 1/2" x 1" 1" x 1" x 1"	7	N	Y	Y	Y	Y	N	N	N	N	N	N	N	N	Y	
50F	AL-Return	Eggcrate	N/A	1/2" x 1/2" x 1/2" 1/2" x 1/2" x 1" 1" x 1" x 1"	8	N	Y	Y	Y	Y	N	N	N	N	N	N	N	N	N	
50R-SS	304 SS-Return	Eggcrate	N/A	1/2" x 1/2" x 1/2"	1	Y	Y	Y	Y	Y	N	Y	N	N	Y	Y	Y	Y	N	Y
50F-NT	AL-Return	Eggcrate	N/A	1/2" x 1/2" x 1/2" 1/2" x 1/2" x 1" 1" x 1" x 1"	NT	N	N	Y	Y	Y	N	N	N	N	N	N	N	N	N	Y
50FF	AL-Filter Return	Eggcrate	N/A	1/2" x 1/2" x 1/2"	1	N	N	Y	Y	Y	N	N	N	N	Y	N	N	N	N	
50FF	AL-Filter Return	Eggcrate	N/A	1/2" x 1/2" x 1/2"	3	N	N	Y	Y	Y	N	N	N	N	N	N	N	N	N	Y
8R	Stl- Return	Perforated	N/A	3/16" Dia. Holes On 1/4" Centers	1	Y	Y	Y	Y	Y	N	Y	Y	Y	Y	Y	Y	Y	N	Y
8R	Stl- Return	Perforated	N/A	3/16" Dia. Holes On 1/4" Centers	3	N	N	Y	Y	Y	N	N	Y	Y	N	N	N	N	N	Y
8F	AL- Return	Perforated	N/A	3/16" Dia. Holes On 1/4" Centers	1	Y	Y	Y	Y	Y	N	Y	Y	Y	Y	Y	Y	Y	N	Y
8F	AL- Return	Perforated	N/A	3/16" Dia. Holes On 1/4" Centers	2	N	N	Y	Y	Y	N	N	Y	Y	N	N	N	N	N	Y
8F	AL- Return	Perforated	N/A	3/16" Dia. Holes On 1/4" Centers	3	N	N	Y	Y	Y	N	N	Y	Y	N	N	N	N	N	Y
8F	AL- Return	Perforated	N/A	3/16" Dia. Holes On 1/4" Centers	4	N	N	Y	Y	Y	N	N	Y	Y	N	N	N	N	N	Y
8SS*	304 SS-Return	Perforated	N/A	3/16" Dia. Holes On 1/4" Centers	1	Y	Y	Y	N	N	N	Y	N	N	Y	Y	Y	Y	N	Y
8RF	Stl- Filter Return	Perforated	N/A	3/16" Dia. Holes On 1/4" Centers	1	N	N	Y	Y	Y	N	N	N	N	Y	N	N	N	N	N
8RF	Stl- Filter Return	Perforated	N/A	3/16" Dia. Holes On 1/4" Centers	3	N	N	Y	Y	Y	N	N	N	N	N	N	N	N	N	Y
8FF	AL- Filter Return	Perforated	N/A	3/16" Dia. Holes On 1/4" Centers	1	N	N	Y	Y	Y	N	N	N	N	N	N	N	N	N	Y
8FF	AL- Filter Return	Perforated	N/A	3/16" Dia. Holes On 1/4" Centers	3	N	N	Y	Y	Y	N	N	N	N	Y	Y	N	Y	N	Y
33RL	HD Steel Return	Single	38	1/2"	1	Y	Y	Y	Y	Y	N	Y	Y	Y	Y	N	N	N	Y	Y
30RL	HD Steel Return	Single	0	"	1	Y	Y	Y	Y	Y	N	Y	Y	Y	Y	N	N	N	Y	Y
33RFL	HD Steel Filter Return	Single	38	1/2"	1	N	Y	Y	Y	Y	N	N	N	N	Y	N	N	N	N	N
30RFL	HD Steel Filter Return	Single	0	"	1	N	Y	Y	Y	Y	N	N	N	N	Y	N	N	N	N	Y
63FL	HD Aluminum Return	Single	30	1/2"	1	Y	N	Y	Y	Y	Y	N	Y	Y	Y	N	Y	N	Y	Y
60FL	HD Aluminum Return	Single	0	1/2"	1	Y	N	Y	Y	Y	Y	N	Y	Y	Y	N	Y	N	Y	Y
T-700	Stl - Door Grille	Single	77	1/2"	1	N	Y	Y	Y	Y	N	N	N	N	N	N	N	N	N	N
CT-700	AL-Door Grille	Single	77	1/2"	1	N	Y	Y	Y	Y	N	N	N	N	N	N	N	N	N	N
1700	AL-Supply Reversible Core	Single	5 up, 15 up, 5 down, 15 up	5/16"	1	N	N	Y	Y	Y	Y	N	Y	Y	Y	N	N	N	N	N
JFA	Stl-Supply-Gang Operated Rear Blades	Double	Adjustable	3/4" Front, 1" Rear	1	N	Y	Y	Y	Y	N	N	Y	Y	Y	N	N	N	N	N
DL	Drum Louver	Vertically Rotating Drum with Blades for Horizontal Adjustment	Adjustable	Varies	1	N	N	Y	Y	Y	N	N	N	N	N	N	N	N	N	N
S300	Direct Spiral Duct-Mounted w Radius End Caps	Double	Adjustable	3/4"	1	N	Y	Y	Y	Y	Y	N	Y	N	Y	N	N	N	N	N
S301	Direct Spiral Duct-Mounted w Radius End Caps	Single	Adjustable	3/4"	1	N	Y	Y	Y	Y	Y	N	Y	N	Y	N	N	N	N	N
US300	Direct Spiral Duct-Mounted w Universal Border	Double	Adjustable	3/4"	1	N	Y	Y	Y	Y	Y	N	Y	N	Y	N	N	N	N	N
US301	Direct Spiral Duct-Mounted w Universal Border	Single	Adjustable	3/4"	1	N	Y	Y	Y	Y	Y	N	Y	N	Y	N	N	N	N	N
S8F	Direct Spiral Duct-Mounted w Radius End Caps	Perforated	N/A	3/16" Dia. Holes On 1/4" Centers	1	N	Y	Y	Y	Y	Y	N	Y	N	Y	N	N	N	N	N
US8F	Direct Spiral Duct-Mounted w Universal Border	Single	Adjustable	3/4"	1	N	Y	Y	Y	Y	Y	N	Y	N	Y	N	N	N	N	N

* Note: 8SS only available with 04 and 26 finishes. Caution: All options are not available in all combinations. Check with your Titus representative for details. Titus reserves the right to discontinue or add options at any time without notice.

SERIES FINISHES, OPTIONS AND ACCESSORIES

Finishes:		Options And Accessories:			
#01	Aluminum Colored Paint	OS	Oversize	PF-SS	Stainless Steel Plaster Frame
#04	Mill Finish	FR	Fractional Size	EQT	Earthquake Tab For Safety Wiring to Support Structure
#20	Envirotherm Color To Match Sample*	C	Concealed Fasteners	SRG	Square-to-Round Adapter for Grilles
#21	Envirothane Color To Match Sample*	DS	Debris Screen 1/4" Square Mesh Galvanized Steel Screen		
#25	Off White*				
#26	White (standard on most models)	IS	Insect Screen 1/16" Square Mesh Galvanized Steel Screen		
#34	Clear Anodized*	FG	Foam Gasket On Back Side of Border		
#84	Black*	PF	Steel Plaster Frame		
#94	Light Bronze Anodized*	PFA	Aluminum Plaster Frame		
#95	Medium Bronze Anodized*				
#96	Dark Bronze Anodized*				

Note: An asterisk (*) indicates additional cost

BORDER TYPES

BORDER TYPE 2
SNAP-IN (PANEL MOUNTED)

Available Module Sizes
24 x 24 inches

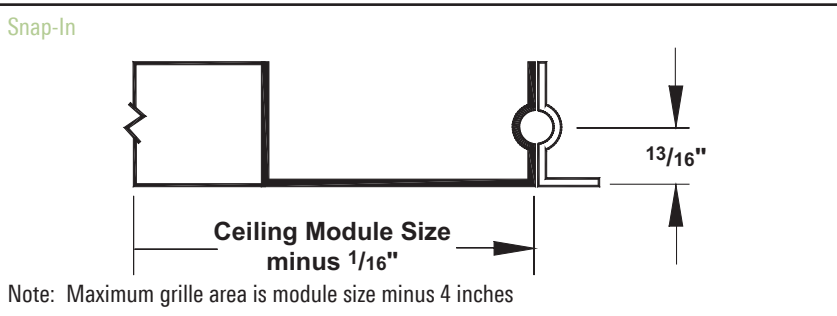

Note: Maximum grille area is module size minus 4 inches

BORDER TYPE 3
LAY-IN (PANEL MOUNTED)

Available Module Sizes
12 x 12 inches 24 x 12 inches
36 x 12 inches 48 x 12 inches
24 x 24 inches 36 x 24 inches
48 x 24 inches

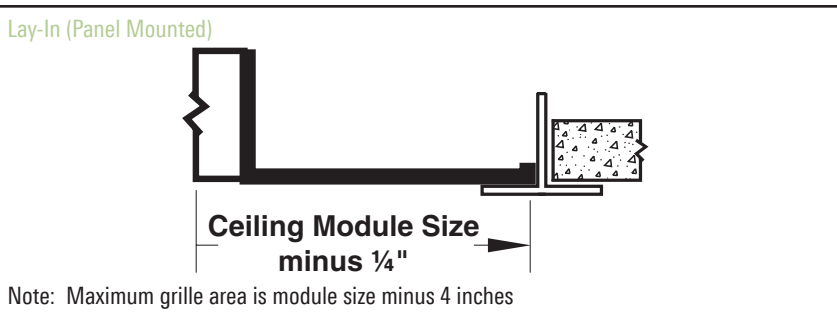

Note: Maximum grille area is module size minus 4 inches

BORDER TYPE 4
SPLINE (PANEL MOUNTED)

Available Module Sizes
24 x 24 inches

Note: Filter grilles not available in all module sizes.

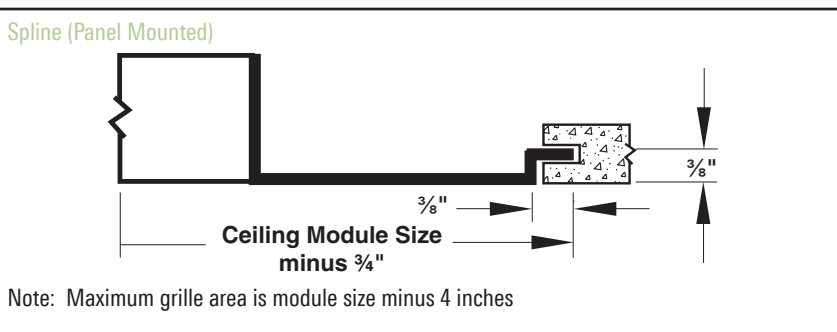

Note: Maximum grille area is module size minus 4 inches

BORDER TYPE 7 (MODEL 50F ONLY)
CHANNEL FRAME

Available Module Sizes
6 x 4 inches through 48 x 48 inches in 2" increments.

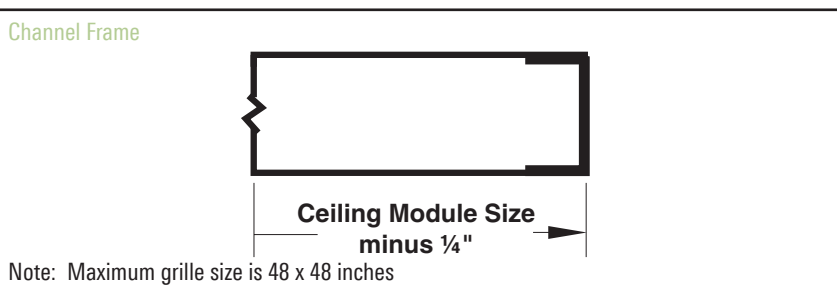

Note: Maximum grille size is 48 x 48 inches

**BORDER TYPE NT
NARROW TEE (PANEL MOUNTED)**

Available Module Sizes
24 x 12 inches 24 x 24 inches

Narrow Tee (Panel Mounted)

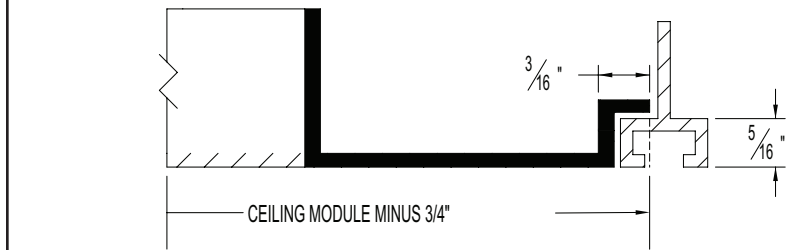

ACCESSORIES

TYPE A FASTENING - SURFACE MOUNT

- Standard For All Border Type
1 Surface Mount Grilles
- Note: For screw hole locations see the chart, "Screw Hole Location Chart"

TYPE C FASTENING - CONCEALED MOUNTING

- Available on Most Models
with Border Type 1

Type A / External Screw

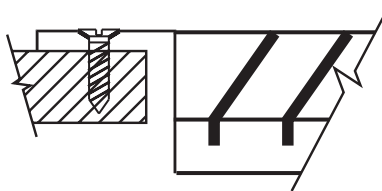

Type C / Concealed Screw

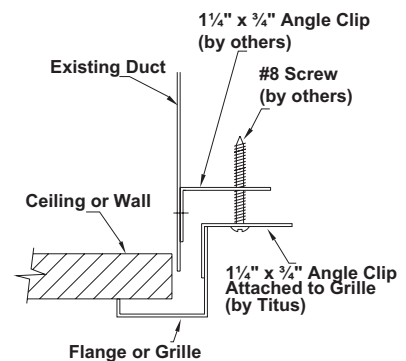

SQUARE-TO-ROUND ADAPTER FOR GRILLES (SRG)

- Available Module Sizes
24 x 24 inches
- 24 gauge galvanized steel construction
 - Flat black finish
 - 2-1/2" beaded inlet
 - Factory assembled to grille

Square-to-Round Adapter for Grilles (SRG)

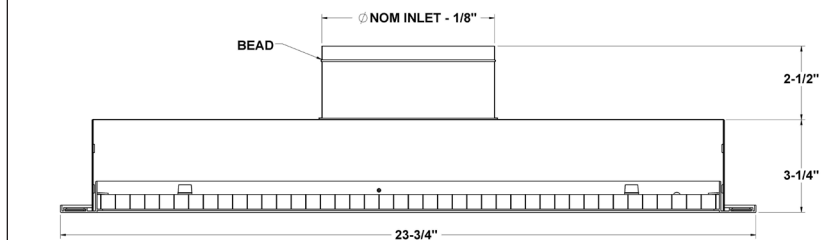

24 x 24 Module Size	
Nominal Grille Size	Nominal Round Inlet Size
22 x 22	6
	8
	10
	12
	14
	16
	18
20	

HINGE LOCATIONS

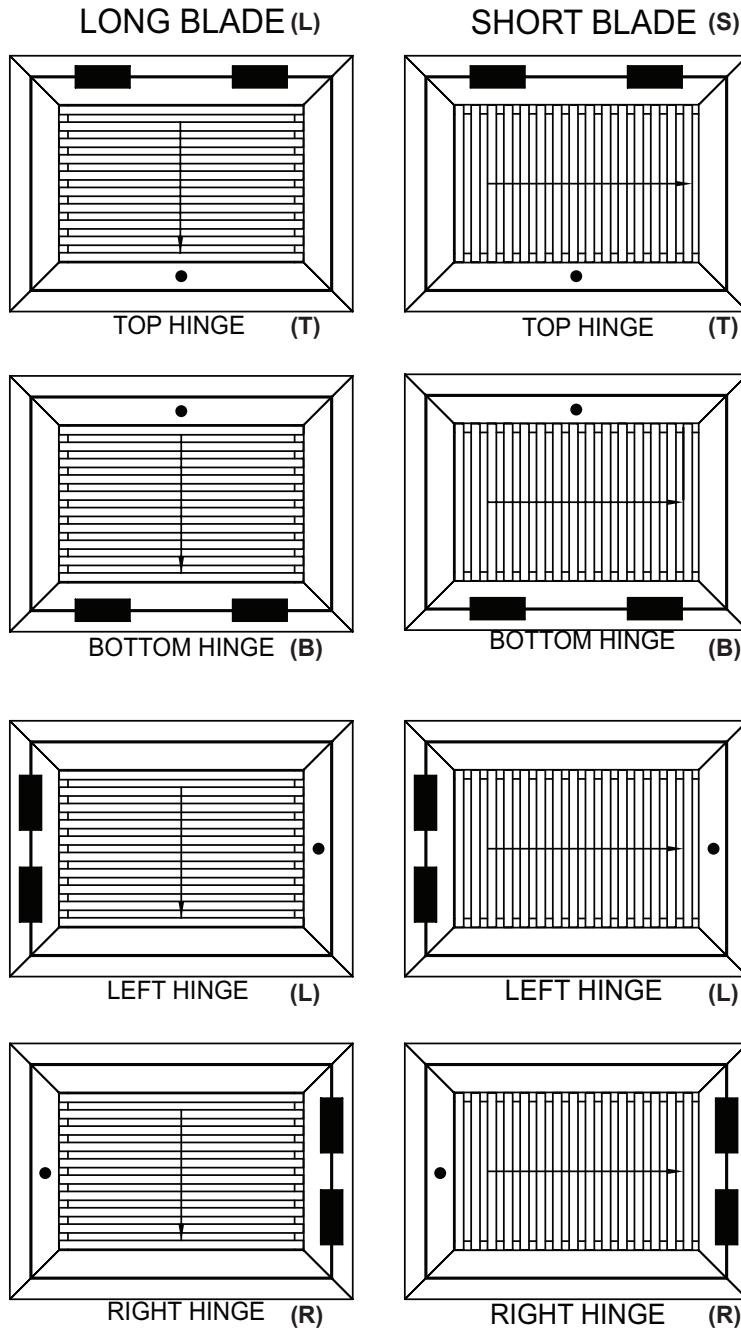

ARROWS SHOW BLADE DEFLECTION



Notes

specialized grilles

